

CARL BOSCH

The development of the chemical high pressure method during the establishment of the new ammonia industry

Nobel Lecture, May 21, 1932

The eminent distinction of the Nobel Prize award which imposes on me the pleasant duty of delivering a lecture to you to-day is in recognition of the development of the high pressure techniques, i.e. the methods used to perform chemical reactions at elevated temperature under pressures of 100 atmospheres and higher.

The technical development of these processes within the I.G. Farbenindustrie concern, a task with which I have been entrusted for about 25 years, posed a profusion of scientific, technical and economic problems the solution of which occupied hundreds of scientists and which affords a living to many thousands of people.

I can only report here on a small section of our sphere of work and with an eye to the motives underlying the award of the prize I have chosen to discuss the solution to the question of apparatus.

Partly as a result of the Lecture given by Haber here in Stockholm in 1920 it has been learned that in 1908 he approached the Badische Anilin- und Sodafabrik with the suggestion to attempt the technical synthesis of ammonia from hydrogen and nitrogen under high pressure. In the course of his studies on the position of the equilibrium in the system ammonia \rightleftharpoons hydrogen + nitrogen he ascertained that the foreseeable shifts in equilibrium for high pressures actually occur in favour of the ammonia, but - and this was a particularly encouraging and for us decisive fact - he also found that osmium and uranium markedly accelerated the attainment of the equilibrium and brought it about at a far lower temperature than the catalysts exclusively used hitherto, i.e. manganese, iron, platinum, etc.

When the management at the time entrusted me with the task of expanding the conversion of this high pressure synthesis to an industrial scale with a view to its economic application, it was obvious that there were three main problems which had necessarily to be settled before the construction of a

plant could be undertaken. These were: supply of raw materials, i.e. of the gases hydrogen and nitrogen, at a lower price than hitherto possible, the manufacture of effective and stable catalysts, and lastly the construction of the apparatus. These problems were dealt with simultaneously.

To begin with, sufficient pure hydrogen for the tests was available from chlorine electrolysis and yielded the required nitrogen-hydrogen mixture by combustion with air. None of the then known hydrogen processes was suitable for large-scale manufacture. We examined all of them but without exception they were too expensive or yielded insufficiently pure gases. It must not be forgotten that the procurement of hydrogen is the largest item in the prime cost, at least nowadays since because of the efficiency of the high pressure synthesis the conversion of the ready-made gas mixture into ammonia is only a minor cost factor. Since we were dependent on coal as a starting material we at once decided on the sole eligible source in our situation, water gas from which nowadays, after a short transition period - separation of the hydrogen by Linde's low temperature liquefaction method - hydrogen is manufactured in enormous quantities by a catalytic process developed by us.¹

The accomplishment of the second task was no less significant. Osmium, a very good catalyst, was difficult to maintain since when in its active, i.e. finely disperse, form it comes into contact with air (never wholly avoidable under industrial conditions) it readily volatilizes as osmium tetroxide, but in particular because the whole world's supply amounted to only a few kilograms, hence at best we could have based only a very moderate manufacture on osmium. Uranium was expensive, of course, yet nevertheless obtainable in some quantity but proved extremely sensitive to oxygen and water and it could not, and still cannot, be converted by any means into a form that can be used for a mass-production process. However, as a result of very broadly based series of experiments using our rapidly expanded experimental technique, we succeeded in preparing relatively fast-acting, technically perfect, easily manipulable, stable and inexpensive catalysts, chiefly those with iron as the active substance* which are currently in universal use presumably exclusively for the synthesis of ammonia. They are a completely new type of catalyst, their characteristic being that they no longer consist of pure elements in varyingly fine form, but are mixtures.² It was only after studies extending over many years and also only in the light of recent theoretical knowledge

* Molybdenum, particularly in mixtures, was also found to be an excellent catalyst; D.R.P. 246, 377, October 22, 1910.

that we were able to clarify the specific action of these mixed catalysts, although at the very outset we had formed empirically a broadly correct idea which assisted us not a little in our studies.*

The successful conclusion of the third task, which is the only one I intend to discuss to-day in more detail, related to the apparatus. There were no examples in industry. The only technique, and that of a physical nature, involving high pressures, was Linde's liquefaction of air. The conventional apparatus for this was made from soft soldered copper and was hence unsuitable for temperatures up to 600°C and locally still higher. In true awareness that the manufacture of the apparatus would be one of the most difficult tasks, quite apart from surprises yet to come and soon forthcoming, an immediate start (a typical feature of our work) was made on fitting up a workshop specially adapted to our needs which first had to make the apparatus necessary for the laboratory work. Right from the start this test apparatus was of very serviceable design since the individual tests all took a very long time as it was particularly important to ascertain the stability of the new catalysts in experiments of long duration. We took as our starting point the apparatus used by Haber for his tests and of which I append an illustration (Fig.1). The contact mass, surrounded by tightly packed insulation, is in the centre of the steel vessel which is cooled with ice water. The gas lead, heating arrangement and temperature measuring device are plainly shown in the figure. As this apparatus suffered from many drawbacks for prolonged experiments, it was completely redesigned and finally in this form (Fig. 2) 24 of them were in continuous day and night service for years.

With its aid we were able to conduct the many separate examinations necessary for the discovery of the catalysts and for development to maximum efficiency, which over the years grew to the number of 20,000. With a small model of this sort there are no special difficulties since air cooling ensures the stability of the outer pressure-bearing parts and of course the mechanical stress on the inner parts is only slight.

The state of affairs was soon to change when we started to build a smaller convertor as a production apparatus. Haber had already attempted something

* "The outstandingly potent action of catalysts made in that way... is presumably attributable to the fact that the admixtures referred to dissolve or become finely disperse in the highly heated metal oxide, whereby during the subsequent reduction an otherwise scarcely perceptible skeleton forms within the metal mass and inhibits extremely effectively any deterioration of the surface and hence of the catalytic properties". (Extract from D.R.P., 254,437, April 22, 1910.)

along those lines on a very small scale but had only run it for one or two hours when it failed for design reasons.

We therefore then built an apparatus of which the chief, and for us the most important and interesting part, except for a circulation pump and the ammonia separator, was a contact tube of the shape and size illustrated in Fig. 3 (wall thickness about 30 mm). This tube was heated on the outside. Being cautious we had housed it in a strong, reinforced concrete chamber far away from all the busy centres of activity since in the meantime we had also become familiar with the danger of fires and flarebacks which occur, frequently with spontaneous ignition, when hydrogen emerges at high pressure.

The two tubes drawn by Mannesmann had each done service for 80 hours, then they burst. If we had charged them with osmium instead of with our new catalyst, the world's supply of this rare metal which we had already bought up would have disappeared.

It was found on examination of the burst tubes that they were swollen and it was apparent that owing to some change of the material the inner wall had altogether lost its elasticity and the change had continued until finally the undamaged part became too thin and yielded to the internal pressure. This is illustrated in Fig. 4A. A chemical attack was the first thought. But what could have happened? To begin with, hydrogen seemed harmless, nitrogen being more suspect since, according to the available literature, iron nitride was apt to form and was described as a silvery, brittle compound forming readily from ammonia and iron. Chemical analysis showed no trace of nitrogen in the embrittled material. More detailed information was obtained by metallographic analysis, a test procedure then almost unknown in chemical engineering and with which I was acquainted only because I had begun my career as a metallurgist. The following picture emerged:

Carbon steel, the only suitable type owing to its mechanical strength, has a structure in which carbonaceous perlite is dispersed in a matrix of pure iron (ferrite). In the changed inside of the used tubes the perlite had disappeared and the structure had been destroyed by cracking. Decarburization of the iron had thus occurred and pure, soft iron should have been formed. But that was obviously not the case as the changed material was hard and brittle. Hydrogen was in fact found to have penetrated the iron and formed a brittle alloy, in the same way as carbon forms brittle iron carbide with iron.*

* As subsequent examinations showed the cracking is essentially caused by the decarburization of the perlite with the formation of methane which becomes enclosed in the structure under extremely high pressure and, together with the mechanical stress on the material, loosens the structure.

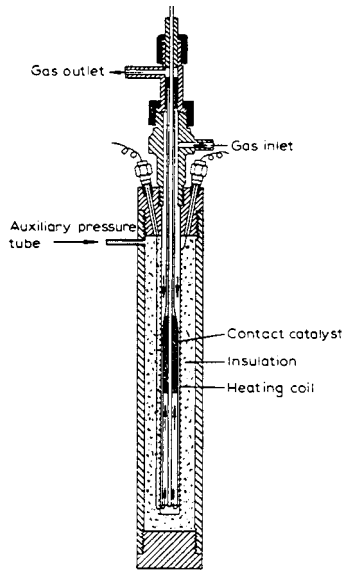

Fig. 1. Haber's experimental convertor, 1909.

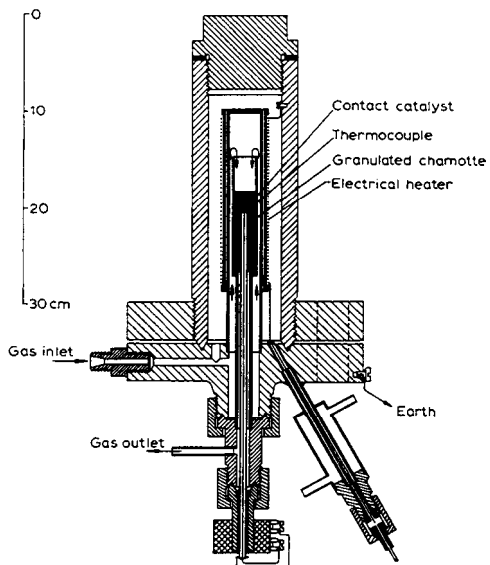

Fig. 2. Laboratory convertor, 1910.

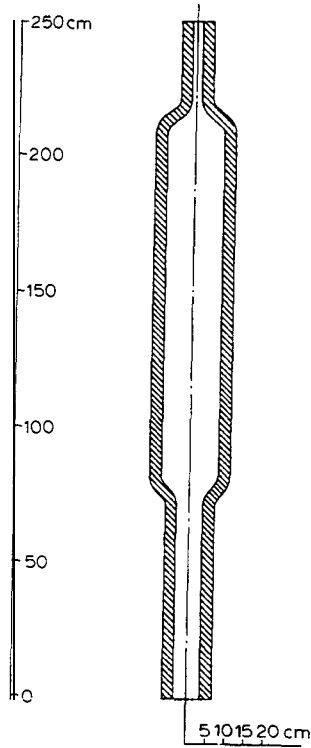

Fig. 3. Contact tube as used in first technical trial, 1910.

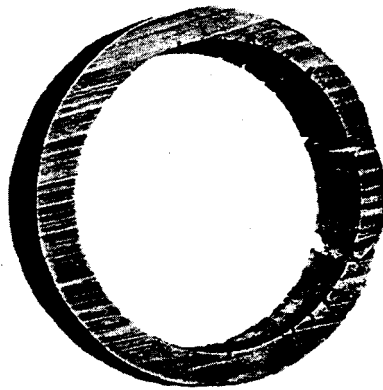

Fig. 4. Unprotected convertor tube, 1910.

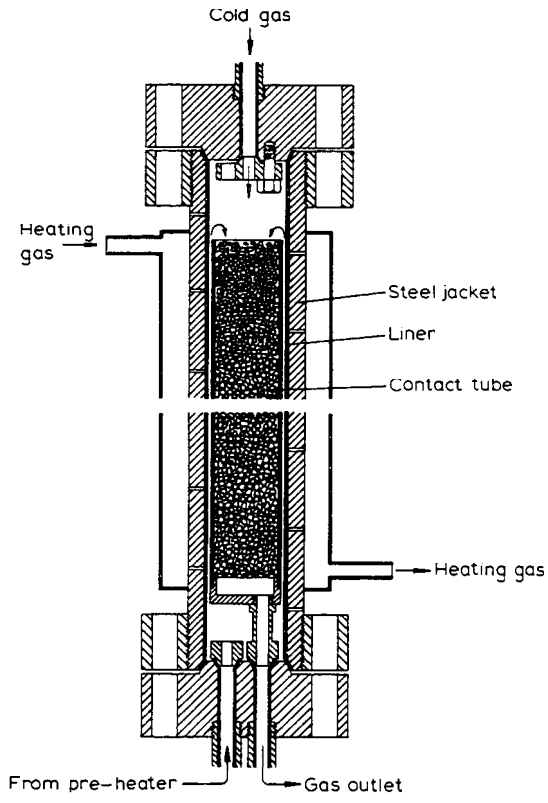

Fig. 5. First convertor with liner and external heating, 1911.

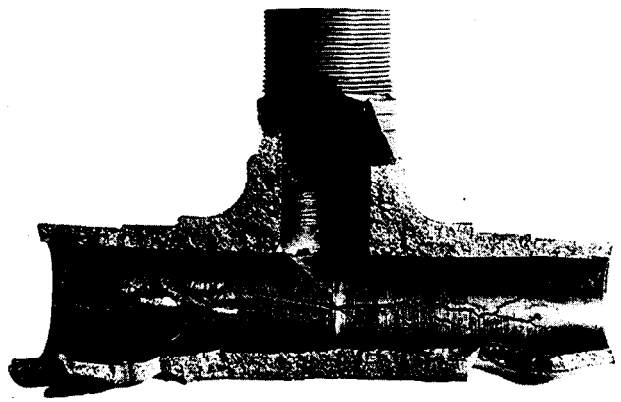

Fig. 6. Brittle fracture of a fitting owing to hydrogen attack, 1930.

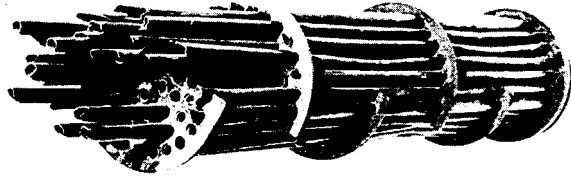

Fig. 7. Destroyed tube cluster from a heat exchanger, 1910.

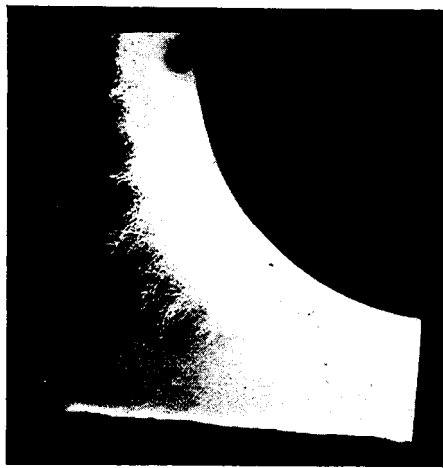

Fig. 8. Hydrogen attack on a mild steel forging. General view, 1930.

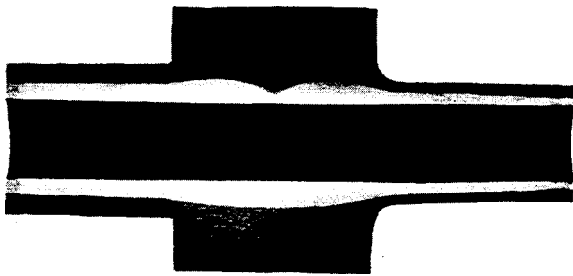

Fig. 9. Effect of wall thickness on decarburization, 1913.

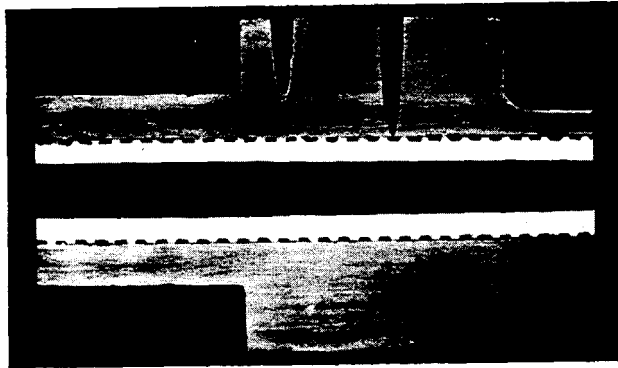

Fig. 10. Protection against hydrogen attack by liner and degasification channels, 1913.

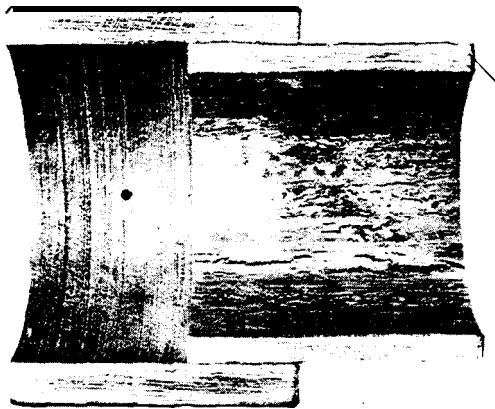

Fig. 11. Steel jacket with liner, 1911.

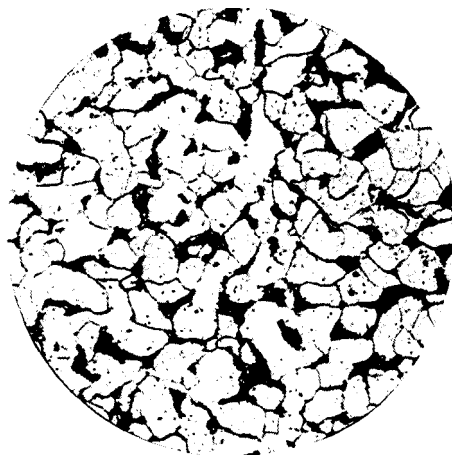

Fig. 12. Fine structure of undestroyed mild steel (x 36).

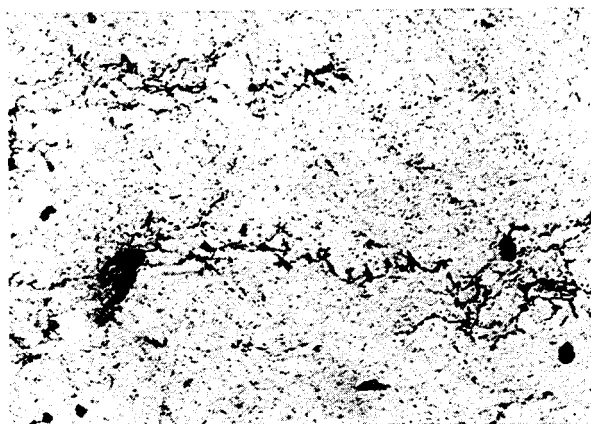

Fig. 13. Unprotected converter tube. Fine structure of destroyed interior, 1910.

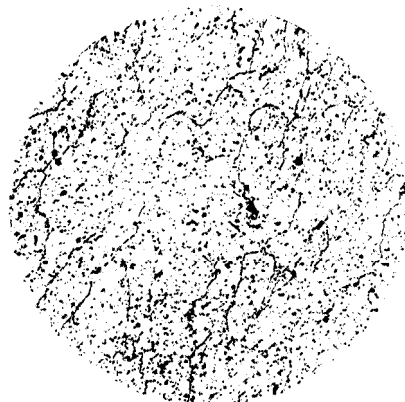

Fig. 14. Fine structure of destroyed 4.8 x 6 mm steel tube from-a heat exchanger, 1910 (x50).

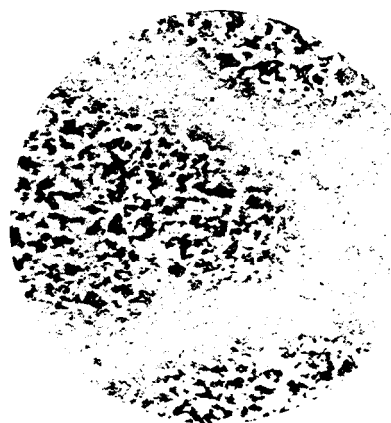

Fig. 15. Hydrogen attack on a mild steel forging. Fine structure in a ramified crack, 1930(x25).



Fig. 16. Hydrogen attack on a mild steel forging. Breakdown-of perlite by decarburization,1930(X50).

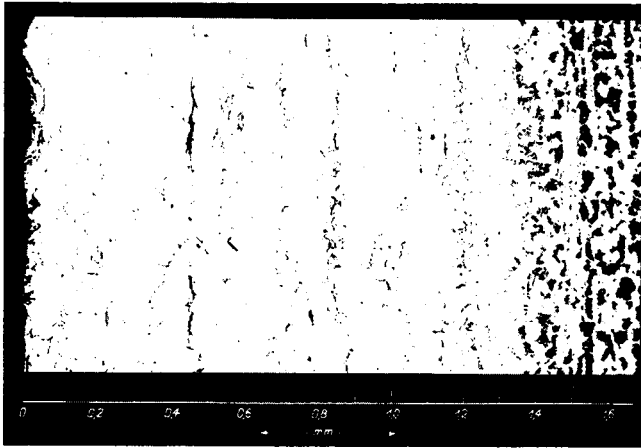

Fig. 17. Effect of hydrogen on structure of mild steel.



Fig. 18. Technical copper (x 40).

We were then in a dilemma. A number of attempts to obviate the difficulties which had arisen were in the first instance unsuccessful or else unpromising. Even when overheating was most painstakingly avoided the same phenomena appeared, albeit after a longer period. Tests of materials in the laboratory revealed that at high pressure and quite high temperature, carbon steel is invariably corroded by hydrogen in the manner outlined. It is just a question of time. In our case at any rate, since the best catalysts then used by us required working temperatures of not less than 400-450°C it was only a matter of hours and days. To dispense with external heating and use stronger internal insulation with cooling on the outside and heating on the inside seemed ineffective and uneconomical, particularly since it transpired that with hydrogen under high pressure all insulations failed - and the good insulations at that - the effect of which is based on their porosity since of course compressed hydrogen has a very high thermal conductivity. Furthermore a systematic study was undertaken of all suitable metals and materials with which it would be possible to protect the steel available to us for pressure-bearing construction material. But these again were either destroyed or permitted very ready trans-diffusion of hydrogen so that no protection was achieved. Only refined steels, as we found in subsequent studies, gave better results so that they were a suitable building material and are still in use to-day.³

Meanwhile we had found a better and quite general solution to the problem of making apparatus with unlimited stability to hydrogen at high temperature under all conditions.

We assumed to start with that the diffusion of hydrogen into the iron, the decarburization of the perlite, and the formation of brittle iron hydride are just unavoidable. They had to be rendered harmless by a modification in design. The wall of the convertor serves two purposes: it holds the pressure of the highly compressed gases, and provides a gas-tight seal. What would be the result of separating these two functions and allocating them to different components? It soon proved practicable to do this. The very first test convertor built on this principle validated this reasoning.

The long-sought solution consisted in fitting a pressure-bearing steel jacket internally with a quite thin lining of soft steel in such a way that as the hydrogen, which of course only diffuses, passes through the thin lining it is able to escape without building up pressure before it can attack the outer steel jacket at the high temperature. This is readily achieved by the grooves produced on the outside when the tube is being turned, and by a large number of holes drilled in the steel jacket through which the hydrogen is free

to emerge. Right at the outset the thin lining tube fits tightly against the jacket under the high pressure and later, when it has become brittle, there is no way of expanding it again so that no cracks occur. Diffusion losses are minimal.⁴

The solution appeared simple and was in fact so but yet the entire development of the process depended on it to a greater or lesser extent. To-day, after 20 years' experience we know that hydrogen still attacks unprotected iron at temperatures even below 300°C and sooner or later causes breakdowns at points where frequently they would not have been expected.

I shall now demonstrate the design for you using lantern slides and then illustrate the destroying action of hydrogen using particularly explicit examples:

Our first convertor dating from March, 1911 with lining tube, still heated on the outside (Fig. 5). The regenerator is located outside the convertor.

Now examples of typical breakdowns: the extensive splintering of the material is immediately noticeable (Fig. 6). The tubes (6 mm outside diameter) had become so very brittle that they shattered on withdrawal of the cluster (Fig. 7). In Fig. 8 the zone destroyed by the hydrogen is shown in white. The finely ramified paths of attack advancing in the material as extremely fine hairline cracks are noteworthy. The next photograph (Fig. 9) shows the etched cross-section of a hollow test rod of carbon steel with a uniform inner cavity and different wall thicknesses. At the top of the thick collar a fine perforation is visible which was drilled through $\frac{4}{5}$ of the wall thickness. The decarburized zone of the material shows up light against the dark intact zone. The extent of the decarburization depends on the existing temperature, the partial pressure (diffusion pressure) of the hydrogen active in the structure and on the magnitude of the mechanical stress.

As measured in absolute terms therefore the decarburization has penetrated further in the thick wall, while measured in relative terms it has penetrated further in the thin wall. Owing to the low local diffusion pressure the corrosion recedes at the cavity.

Fig.10 shows how the hydrogen attack is rendered harmless by lining tube and gas exhaust channels. Removal of the gas has made it impossible for the hydrogen completely to destroy the lining tube or even attack the jacket. Apart from numerous cracks the lining tube (Fig. 11) also exhibits blistering caused by the formation of methane and steam owing to diffusing hydrogen. The steel jacket itself shows no cracking at all but has widened owing to thermal expansion. Microscopic examination of the fine structure affords the best

insight into the destruction. Firstly, in Fig. 12 the fine structure of an intact ingot steel can be seen. The matrix of pure iron (ferrite) is light, the dispersed carbon-containing crystals (perlite) are dark.

A number of photographs then follow which show the destruction of the structure, a very instructive example being Fig. 13. The material is completely decarburized and loosened at the grain boundaries.

In Fig. 14 the material is also completely decarburized and loosened at the grain boundaries. Oxides are embedded everywhere in the structure.

Fig. 15 shows the fine structure of a ramification of the attacked forging in Fig. 8.

Similarly Fig. 16 which brings out particularly clearly the incipient dissolution of the perlite near grain-boundary breakdowns.

The same progression of the effect induced by the hydrogen appears in Fig. 17.

The two following photographs show copper which was tested as material for the jacket and lining, proving inferior to iron. First copper with a normal structure (Fig. 18) and then Fig. 19 showing the structure after brief exposure to the action of hydrogen at high pressure and temperature. After 40 hours the destruction had become so far advanced that the copper, in this case from a regenerator coil, was completely permeable to gas. Besides hydrogen attack on the structure there is a further factor which frequently causes breakdowns, i.e. severe cavitation within the metal (Fig. 20). The hydrogen which has diffused into the material, the methane formed by decarburization and any steam formed by the reduction of oxides are present under high pressure in the structure of the steel.

When the pressure of the ambient gas atmosphere is rapidly released the material readily expands, particularly at higher temperature at sites with small coherence beforehand such as incompletely welded blow holes and pipes or sites where there are large accumulations of slag.

I have already stated that in what are termed refined steels we found a suitable material which finds particular application at points in apparatus which are awkward to protect by a lining. Fig. 21 follows for comparison with iron (ingot steel). Refined steels are merely carbon-containing iron alloys, e.g. with Cr, W, and Ni.

Examination showed that perlite nickel steel is very sensitive to hydrogen attack, in many cases more sensitive even than ordinary ingot steel. The sensitivity rises with increasing nickel content. This influence of nickel can be offset by the appropriate addition of alloying metals such as chromium, tung-

sten, molybdenum, etc. The graph (Fig. 22) shows that for instance a tungsten content of 2% is insufficient compensation and that the loss of strength and expansion increases strongly with the nickel content. A 5% tungsten addition is adequately effective.

Next comes a figure to illustrate the effect of degasification (Fig. 23). It can clearly be seen that the destruction stops short a certain distance from the degasification channels and that the jacket tube is not attacked. In the present instance the jacket and lining tubes are of different materials (jacket tube of ingot steel, lining tube of ingot iron).

A further means to inhibit the attack of hydrogen on the iron is to flush the space between the lining tube and the jacket continuously with nitrogen.⁵ As I have previously mentioned nitrogen is not harmful to iron. The effect of this arrangement is exactly like that of gas exhaustion, as shown in Fig. 24. The method is applied on a wide scale in conjunction with gas exhaustion.

Elsewhere⁶ it was found that instead of the neutral gas a bath of metals, liquid at the working temperature and impermeable to hydrogen, can be used (Fig. 25, scale as in Fig. 24). In this case, however, the separating steel tube is decarburized through its entire wall and loosened at the grain boundaries, hence mechanically completely destroyed.

I now come to the *design of the convertor*.

It was obvious from the outset that the economy of the process necessitated extracting a large proportion of the heat required for heating the gas mixture by exchange from the exhaust gases. Yet the yield of ammonia after a single pass over the contact catalyst was only about $\frac{1}{6}$ of the original mixture.

Although at the beginning of our tests we had counted on compensating for the heat losses by heating the convertor, even with this arrangement the utmost economies had to be made since the amounts of gas passing through are enormous and the heat has invariably to be supplied to the hottest point before the catalyst. Moreover, care had to be taken to avoid an excessive temperature gradient owing to the passage of heat through the convertor jacket since in any case at the temperatures prevailing the strength of steel drops markedly, as shown in Fig. 26. In view of the low conversions involved we dared not count on replacing the heat losses by the heat of reaction alone.

Based on Knietsch's well-known design for the sulphuric acid contact process, the convertor was conceived as shown in Fig. 27. The design reproduced here for the ammonia convertor incorporates all the characteristics of the best modern tube convertor, the heat of reaction being removed as evenly as possible. The counter-current principle in the heat exchange has been retained

without modification. The admission of cold gas at the top enables the reaction to be controlled. The contact chamber is largely subdivided by the regenerator tubes.

At the time the design was shelved because the knowledge that the material is destroyed by hydrogen imposed the need for simplification. Copper regenerator tubes had been thought of and as transpired a few weeks later copper is particularly severely attacked by hydrogen (cf. Fig. 19).

As we were unable to incorporate the whole of the necessary heat exchangers in a convertor, two further regenerators were arranged in front of the contact tube so that the whole arrangement then appeared as shown in Fig. 28. Apart from the cluster of regenerator tubes in the convertor, this design also features a vertical cluster of regenerator tubes connected to a double spiral. The tubes between the convertor and the vertical regenerator were lined. The double spiral, too, was later dropped because the temperatures arising in it led to destruction by hydrogen and its resistance to flow was very high. A second vertical regenerator then replaced the double spiral.

The contact tube was heated on the outside using gas. With this apparatus quite prolonged operation was possible for the first time. But the hope that we were now at the end of all our difficulties was not fulfilled. Even without being destroyed by hydrogen, the steel jackets of the convertors were in the long run unequal to the high pressure at the high temperature imposed by the external heating. They buckled and cracked and the result was a series of heavy explosions which we were able to render harmless of course by accommodating the tubes in explosion-proof chambers but the continual high repair costs threatened the economics of the process. A different answer had thus to be found and consisted in supplying the heat from inside. Even then we still did not trust electrical inside heating as we were faced with unavoidable high losses to avoid overheating of the jacket. We thus tried gas heating by burning hydrogen (synthetic gas) with admitted air in the convertor. A certain amount of water was formed but did not appear to harm the contact catalyst. At any rate this was the lesser evil.

To avoid the risk of an explosion of the hydrogen-air mixture with every expectation of its being extremely violent, we studied the problem on the arrangement shown in Fig. 29. The flame in the pressureless apparatus was a pale greyish blue, at a pressure of 100atm. the flame appeared a shiny bright blue.

The ultimate version of a convertor appeared as in Fig. 30.

The figure illustrates the design of a large convertor of 800 mm inside

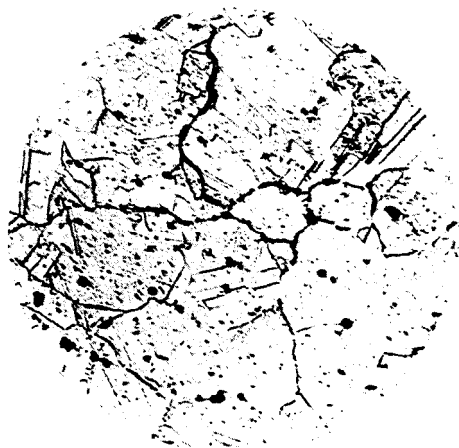

Fig. 19. Structure of copper tube destroyed by hydrogen. (x36).

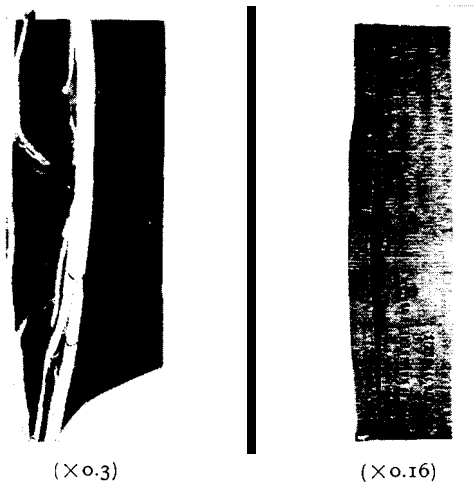

Fig. 20. Cavitation of sheet iron and rolled stock, 1913.

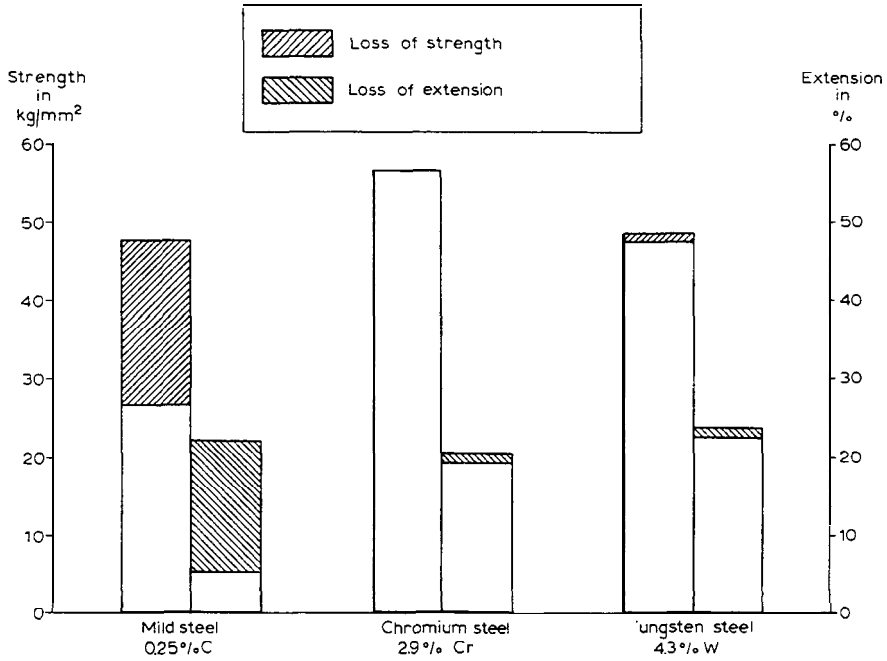

Fig.21. Loss of strength and extension after treatment for 24 hours in hydrogen at 580° C and 150 atm., 1911.

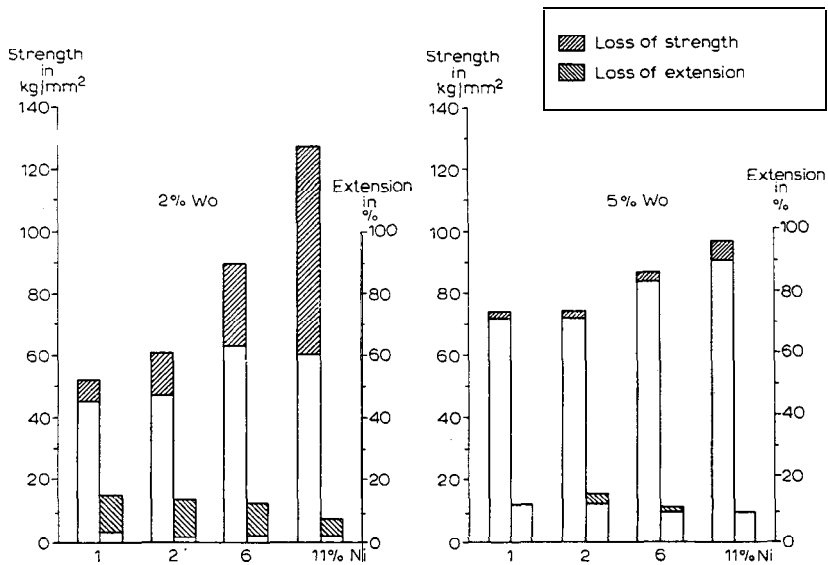

Fig.22. Effect of nickel content on hydrogen attack on nickel tungsten steel, 1916.

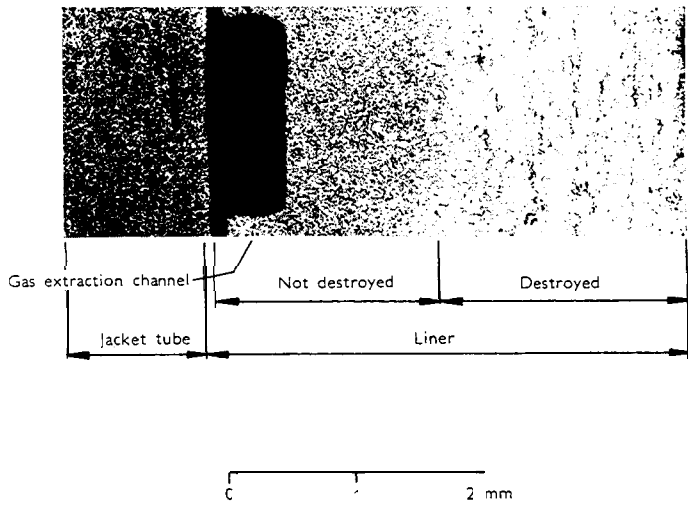

Fig. 23. Fine structure of a liner with degasification channels, 1910.

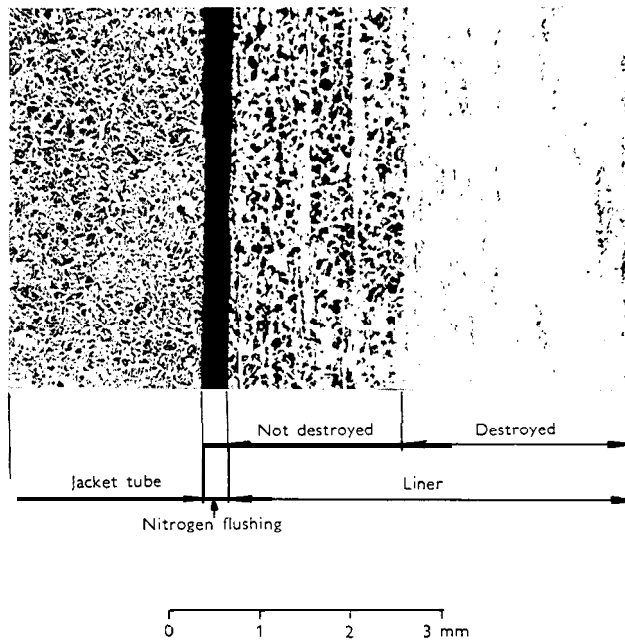

Fig. 24. Protection of jacket by neutral gas.

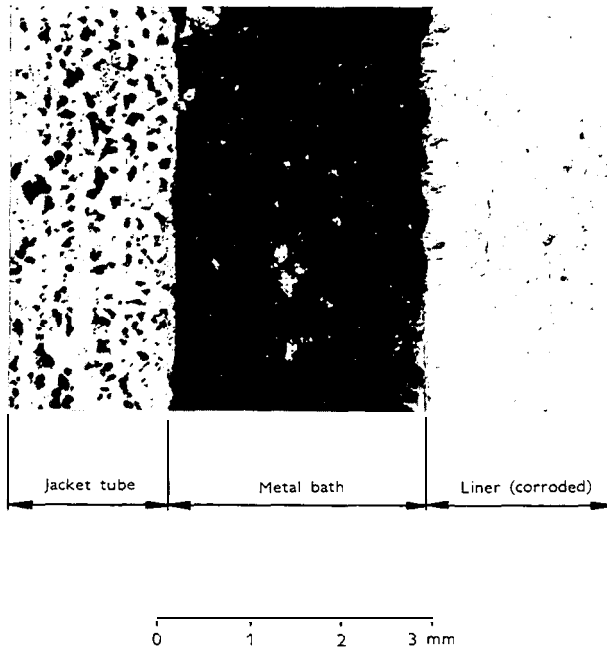

Fig.25. Protection of jacket by metal bath.

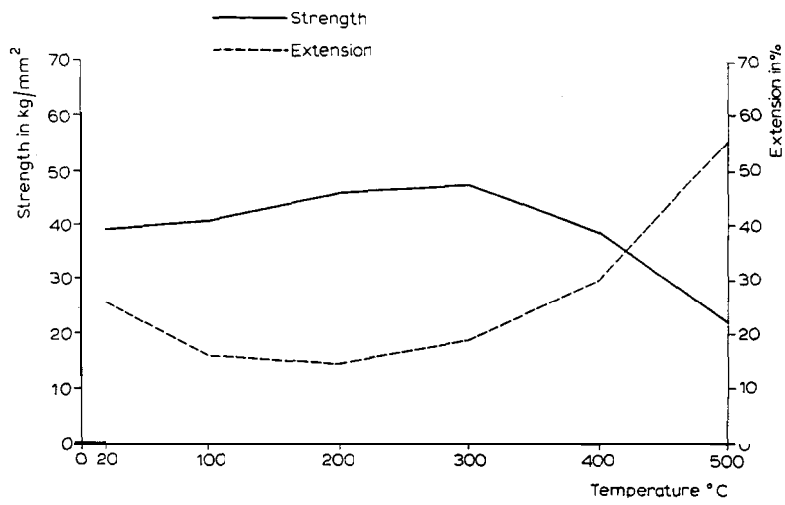

Fig. 26. Tensile strength and extension of mild steel (Bach, 1904).

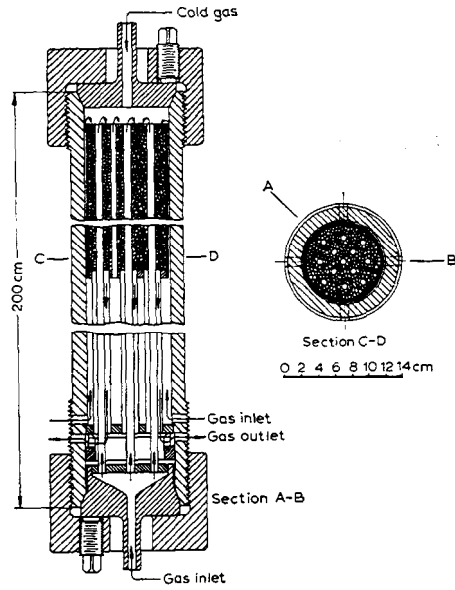

Fig. 27. Converter, 1910.

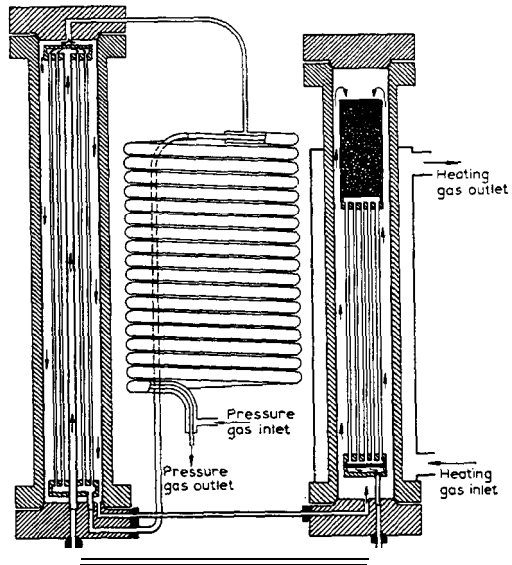

Fig.28 Converter with heat exchanger and external gas heating, 1911.

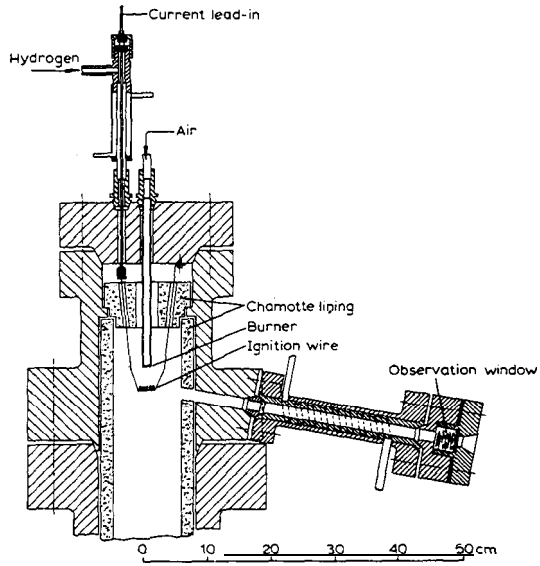

Fig.29. Experimental apparatus with internal gas heating under pressure, 1911.

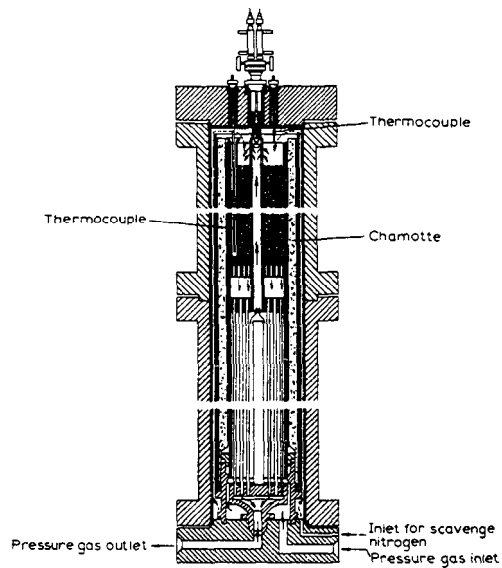

Fig. 30. Converter with nitrogen flushing, 1916.

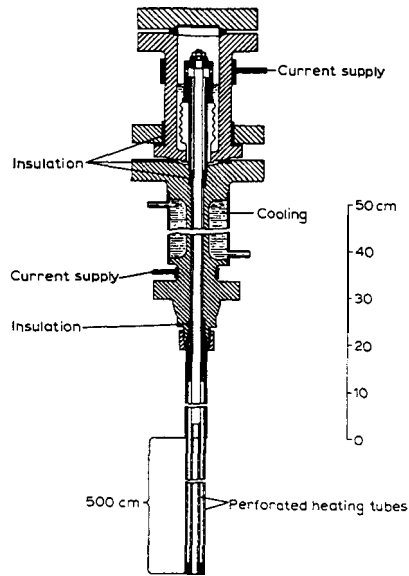

Fig. 31. Electrical burner, 1918.

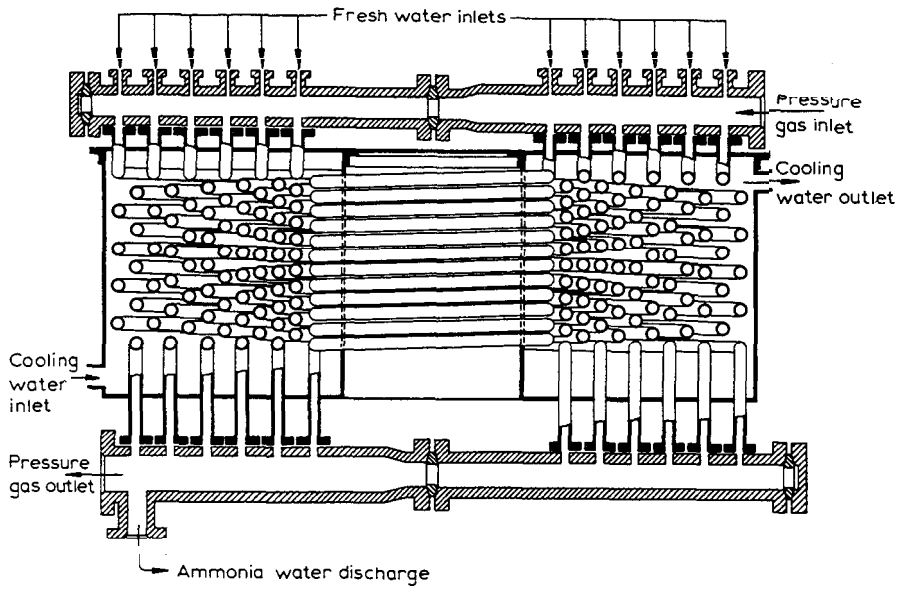

Fig. 32. Coil absorber, 1913,

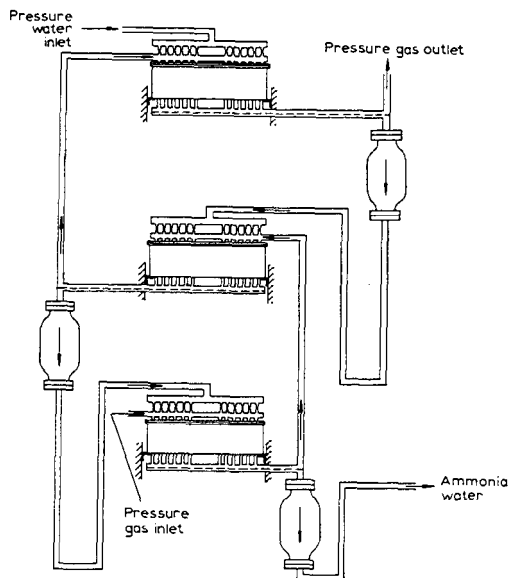

Fig. 33. Coil absorption, 1915.

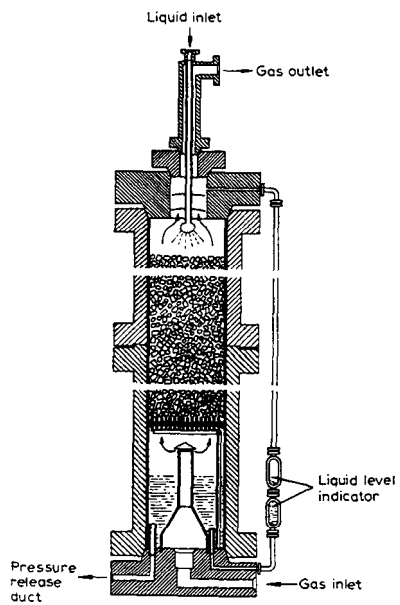

Fig. 34. Large ammonia absorber, 1920.

diameter - an "800 oven" - with gas heating on the inside, a central tube and nitrogen flushing. The inside system of gas heating was retained until 1922. During the more than 10 years that this method was used under production conditions, no explosions occurred in the convertors. Observations of the thermocouples, particularly the one fitted to the burner, showed when it was necessary to apply additional heating to the oven, even below a pressure of 200 atm., by forcing in air.

As we moved to bigger and bigger production units it was found that beyond a certain size it was possible, given good heat exchange, to offset the heat losses by the heat of reaction. This represented quite a considerable advance for then we were able to dispense entirely with continuous heating during the operation. It was just a matter of bringing the convertor to the correct initial reaction temperature. Gas heating had essentially the drawback that during the heating-up period the gas circuit had to be reversed with respect to normal operation in order to keep the combustion products away from the contact area, often causing stoppages owing to cracks in the convertor lining. Moreover the heat had to be applied across a high gradient to the gas at a relatively small point. These drawbacks were overcome by the electrical heater, about 5 m long, accommodated in the central tube (Fig. 31).

As the design of the convertors advanced we also turned our attention of course to the other parts of the high pressure apparatus. There was firstly the matter of withdrawing from the circuit the ammonia formed. The answer was to use water in the following way:

To prevent the entailment of water, water and gas flowed in the same direction through a spiral tube system cooled on the outside (Fig. 32). However, to achieve a counter-current and obtain the maximum concentration of ammonia water with the optimum scrubbing effect, three such systems were stacked one on top of the other which then operated on the counter-current principle (Fig. 33). Later it was learned how to build simple scrubbers (Fig. 34). This was an obvious answer but only practicable after long experience.

To-day, to cut down transport costs, a large part of the ammonia is liquefied free from water by intense cooling.

Initially the high pressure compressors were a great source of worry. Hitherto large compressors had only been used in engineering for compressing air. In the main they were used to produce compressed air for running compressed air locomotives in mines and for Linde type air liquefaction plants. These compressors were only designed in modest sizes. The chief trouble, however, was that little attention had been paid to the stuffing boxes. In the case of air,

leaks were not important and a brief stoppage was accepted. Matters are different where hydrogen and the sensitive contact process are concerned. Losses of hydrogen mean money and the risk of explosion, and the contact apparatus could not stand stoppages. Probably all the designs then built were tried out by us and in years of work, on the basis of the experience which we gained from those small compressors which ran for not more than half a day without stopping, we succeeded in building the gigantic 3,000 horse power units which function reliably and without stoppage for 6 months, after which they receive their regular, periodic clean. At this juncture I should like to stress how important completely smooth running is for the synthesis of ammonia. Every stoppage at a single point affects the entire plant and after a stoppage it takes hours until everything is back to normal. It is no exaggeration for me to say that, technically speaking, it depends entirely on smooth, continuous operation whether the process is economical. It has taken us years to reach that point. Of particular assistance here were the *monitoring instruments* to which we turned our attention right at the outset since it soon transpired that it was possible to follow the events in the convertors only by continuous recording. Nowadays that is obvious and most of the instruments are even available commercially but in those days we had to build and try them all out ourselves. Of the abundance of characteristic examples I shall deal only with a few. Besides accurate temperature monitoring at all points in the convertor by simple thermocouples, and the determination of the ammonia, the main factor of interest is the intensity of the gas stream. A *pressure balance*, as it is termed, permits measurement of the gas stream with the maximum precision at the highest pressures (Fig. 35). Measurement of the amounts of gas, steam and liquid under high pressure necessitates recording the pressure difference arising in the jets or orific plates in the pipe line, the square root of which is proportional to the amount. The pressure balance records these square roots by means of a semi-circular, U-tube housed in one of the balance arms and half filled with mercury. The pressures prevailing in front of and behind the orifice plate are applied to both ends of the balance via elastic capillary tube solenoids. The square of this value is plotted on a cylinder via a swinging lever fitted with a guide.

The composition of the circulating gas stream also has an important bearing on the process. It is indicated by the automatic *density recorder* (Figs. 36 and 37). The density recorder is based on Bunsen's law relating to flow and both controls the proportion of the mixture of hydrogen and other gas admixtures, and accurately records the gas density which has to be allowed for when the

amount of gas is measured by means of a jet. Errors induced by temperature and pressure are compensated by comparing the flow volumes of the gas mixture and a standard gas (air) in the same times and at the same temperatures.

It is very important to monitor the process for any oxygen content, not only because of the explosion risk but also because of the steam created in the hot catalyst which, as we now know, reduces the yield.

The procedure here is as follows (Fig. 38). To record small contents of oxygen down to 0.01% the hydrogen mixture is guided through an electrically heated combustion tube with a differential thermopile, the even numbered junctions of which carry collars of catalyst of minimum thermal capacity where the reaction

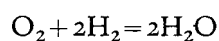

produces a temperature rise with respect to the uneven numbered junctions. The thermoelectric current generated is recorded and trips an alarm on reaching a given danger level. With the addition of electrolytic hydrogen the instrument records the oxygen content of Linde nitrogen. It is used also for other exothermic reactions, e.g. to detect benzine vapour in the air.

No less attention had to be paid to monitoring the carbon monoxide content since next to sulphur this is the greatest enemy of the iron contact catalyst.

The water-gas equilibrium, which in our process at low temperature and with excess water vapour we displace to the right hand side of the equation

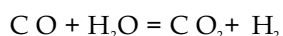

is at about 2% CO under technical conditions.

After the carbon dioxide has been removed by scrubbing with water under pressure, carbon monoxide is removed by means of an ammoniacal solution of cuprous oxide. The carbon monoxide dissolved in this solution is driven off by gentle heating and reduction of the pressure. A solution containing just cuprous oxide precipitates metallic copper since carbon monoxide has a slow reducing action. To avoid that effect a little oxygen is continuously added to maintain the solution at an accurately controllable concentration of cuprous oxide. The apparatus used is that shown here (Fig.39). The apparatus monitors the degree of oxidation of the cuprous oxide solution which absorbs the carbon monoxide. The blue cupric ions of the solution flowing through

the cell absorb part of the light from an incandescent lamp striking a thermopile. The difference between the thermoelectric power of this thermopile and a second one irradiated via a standard filter is recorded. It is approximately proportional to the cupric ion concentration and thus to the amount of oxygen taken up by the solution.

The construction of such a large interconnected apparatus as at present installed in our works at Oppau and Leuna and the thousands of metres of tubing, and the thousands of flanges and valves associated with it also necessitates a special study, of course. Above all, everything has to be gas-tight and the appropriate measures have been so successful that the gas losses are just sufficient to prevent the argon content originating from the air and the accumulating methane attaining too high a level in the circulating system.

The apparatus has to be perfectly reliable and permit extremely rapid shut down and evacuation of parts in the event of stoppages. Over the years we have been able to cull sufficient experience, especially during the war when the Oppau works were bombed night after night, and we are still of the opinion today that one cannot be too careful. Consequently we have always played for safety, and ultimately took over ourselves the design and a major part of the manufacture of the fittings in our own workshops. Apart from seamless tubes, only steel forgings are used. Briefly I should like to cite a few examples (Figs. 40, 41 and 42).

In the quick-acting valve (Fig. 40) the magnetic coil mounted on a compression-resistant jacket of V2A non-magnetic steel is energized by contact manometers operating on the steady flow principle, in the event of a tube breakage. The self-closing valve (Fig. 41) with spring release and by-pass valves is automatically sealed off at one side or the other by the gas stream when the rate of flow becomes too high owing to tube breakage.

The slide valve illustrated in Fig. 42 which is designed as a venturi tube is rapidly closed in the event of tube breakage by the descending piston and by the release of pressure via the needle valve on the adjustable pin. When the exhaust channel milled in the slide valve pin enters the false bottom, the closing action is retarded. Two circulating pumps (Figs. 43 and 44) are worthy of mention as examples of further important new designs. The design in Fig. 43 is marked by the passage of the piston rod through the cylinder head to prevent as far as possible deposits of liquid and dust settling on the stuffing box. The feature of the rotating gas circulating pump (Fig. 44) is that the electric motor and the centrifugal pump function in a pressure vessel at 200 atm.

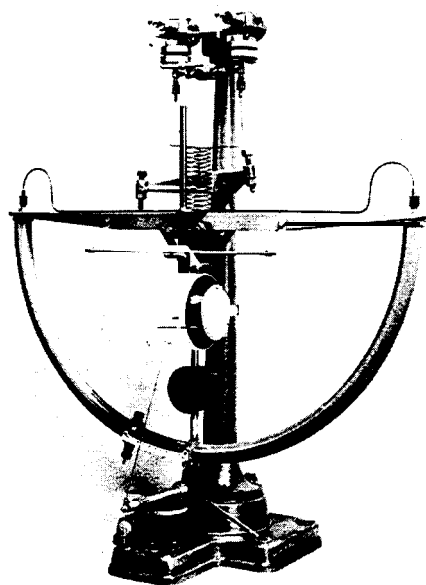

Fig. 35. Mercury pressure balance for gas, 1914.

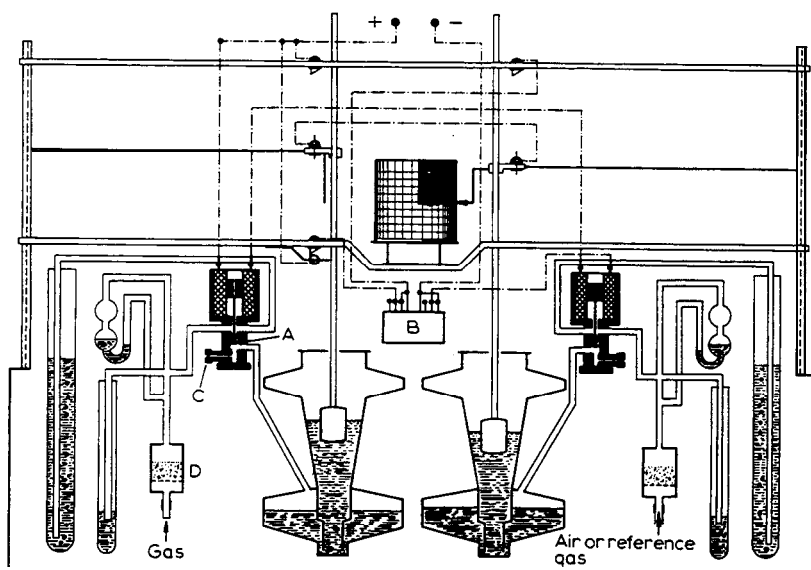

Fig. 36. Gas density recorder (A = three-way valve; B = d.c. relay; C = gas jet; D = filter), 1914.

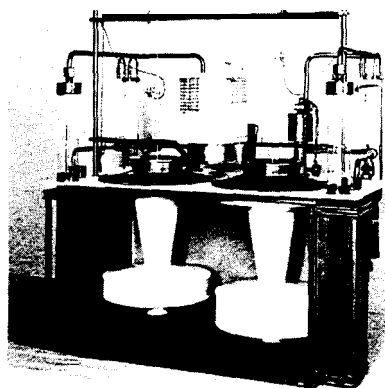

Fig. 37. Gas density recorder, 1914.

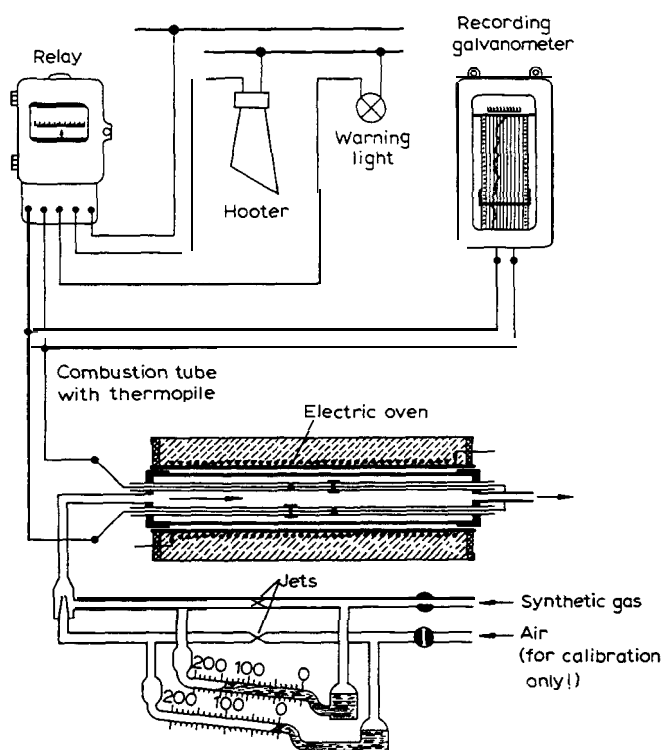

Fig. 38. Instrument to detect traces of oxygen by thermal effect, 1919.

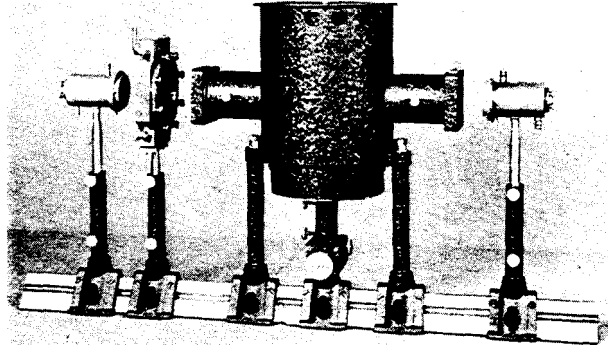

Fig. 39. Colorimeter to measure oxygen in copper solution, 1921.

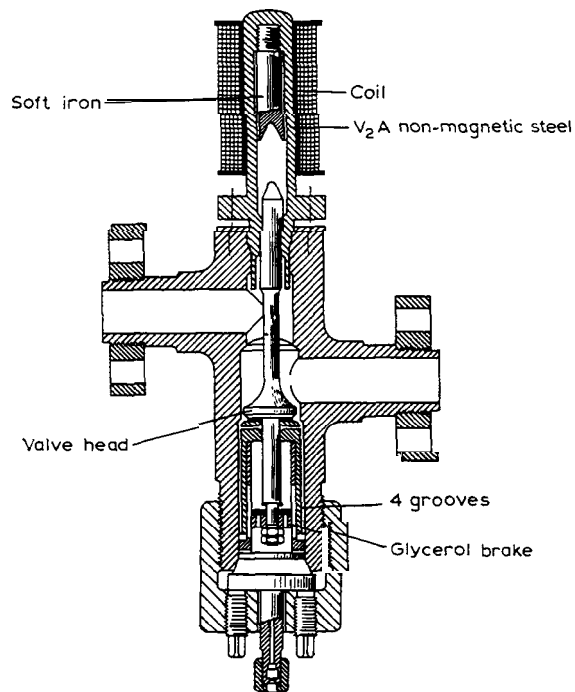

Fig. 40. Magnetically operated quick-acting valve, February 1913.

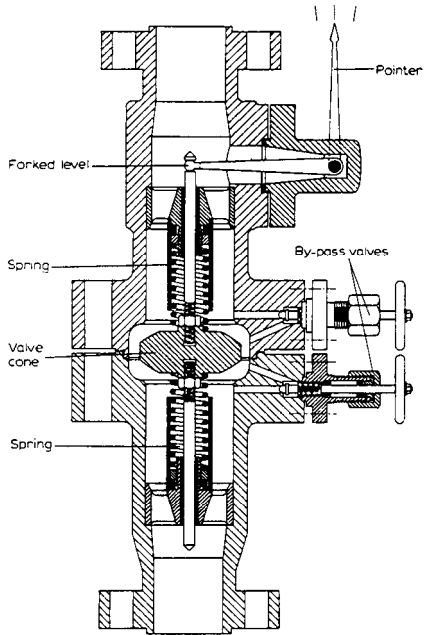

Fig.41. Self-closing valve, October 1912.

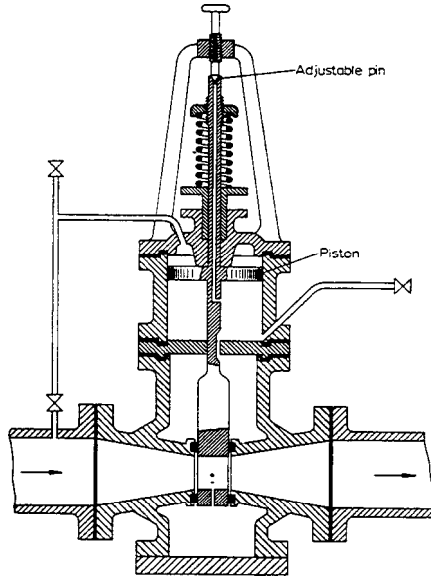

Fig.42. Quick-acting slide valve, 1926.

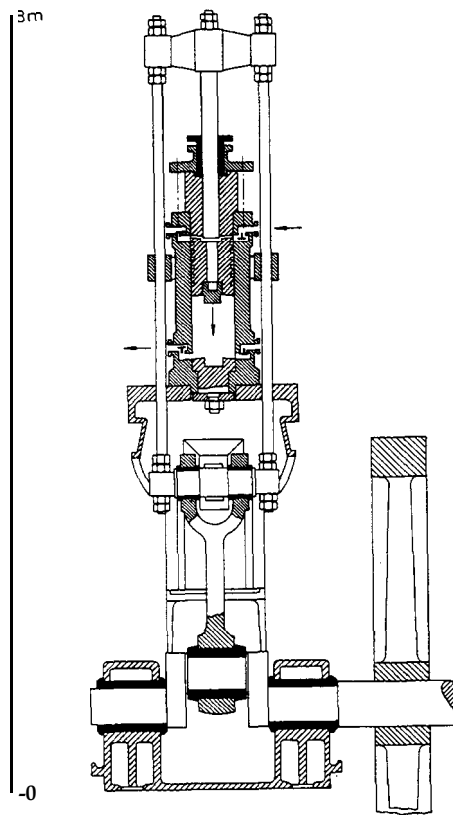

Fig. 43. Large piston circulating pump.

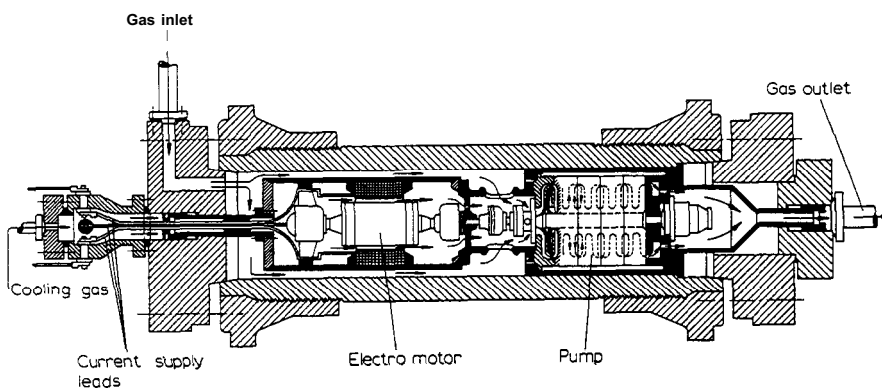

Fig.44. Rotary gas circulating pump, May 1922.

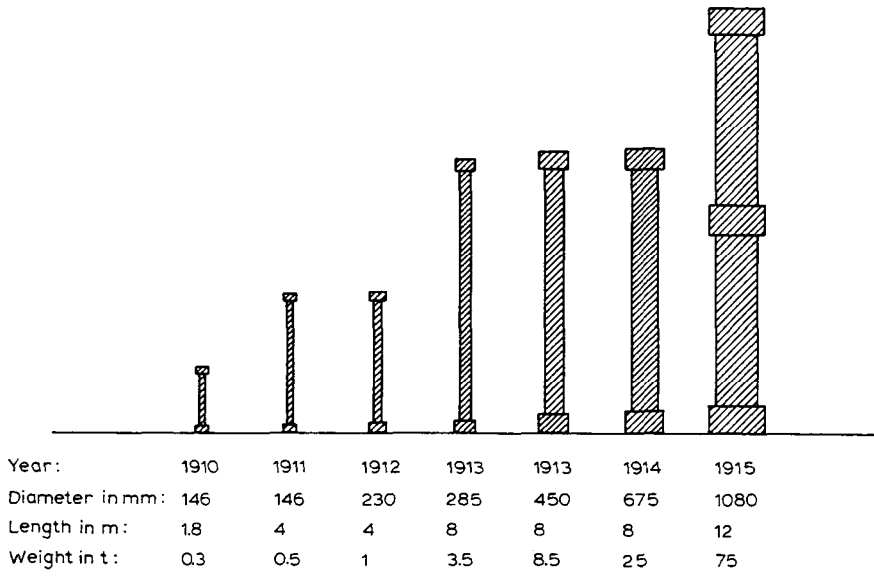

Fig.45. Increasing size of ammonia convertors, 1910-1915.

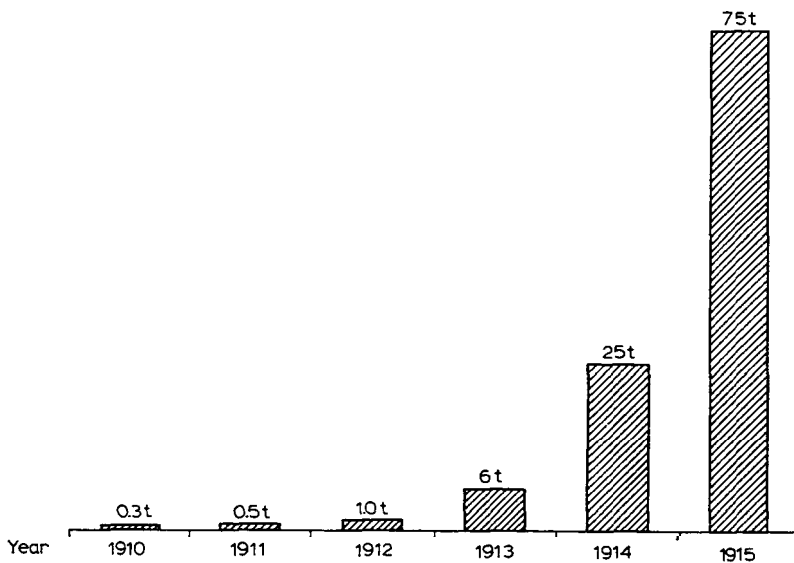

Fig.46. Increasing size of ammonia convertors, 1910-1915.

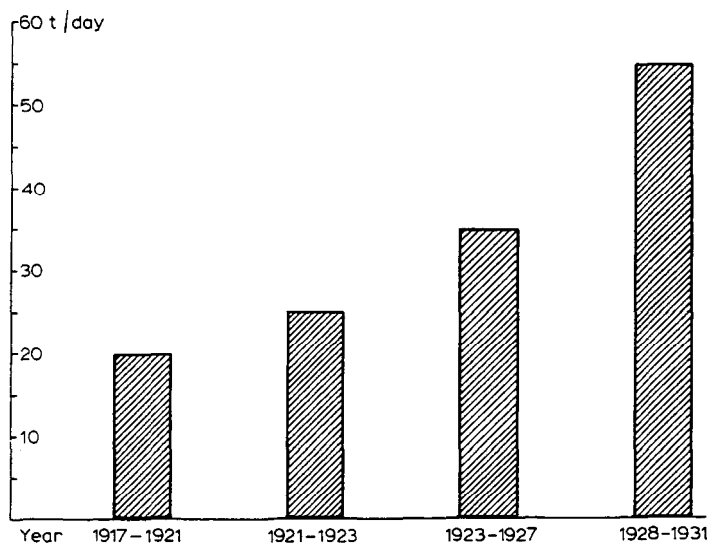

Fig.47. Output of large convertor in tons of nitrogen per day, 1917-1931.

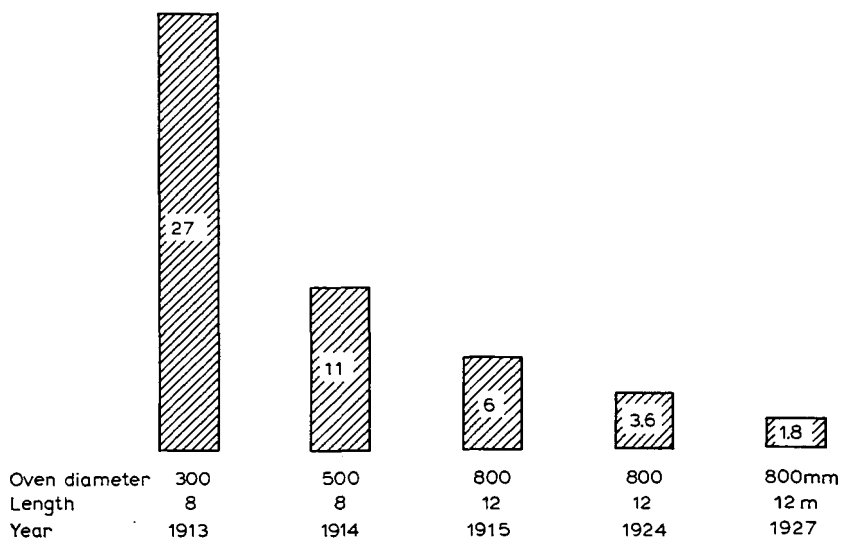

Fig.48. Weight of steel for equal production of nitrogen, 1913-1927.

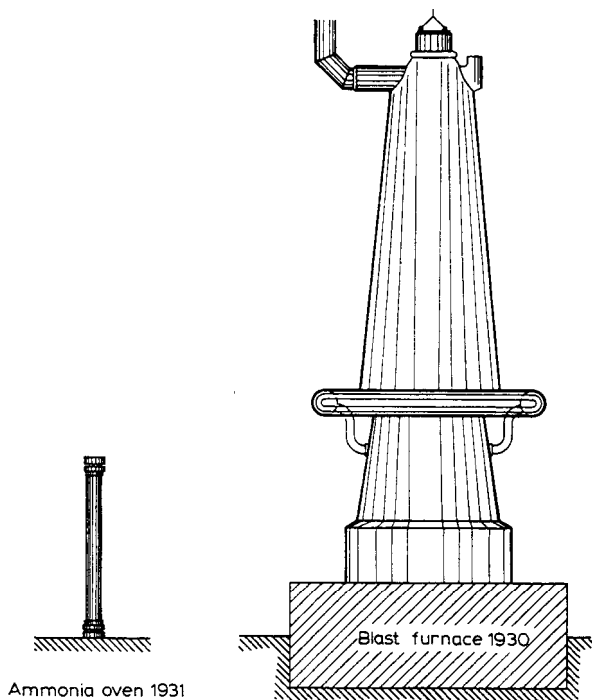

Fig.49. Comparison of sizes of blast furnace and ammonia oven for same throughput value, 1930.

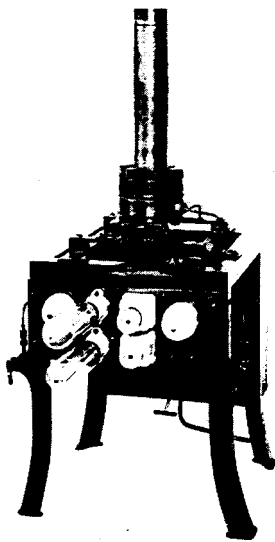

Fig. 50. Laboratory converter, 1910.

In broad outline that is how the high pressure process for the synthesis of ammonia developed.

As a further illustration of the developments that have come about over the years I would like you to compare a few figures: Figs. 45 and 46 vs. Fig. 47.

The increase in the capacity of the large convertor from 1917 to 1931 (Fig. 47) was achieved by altering the design of the lining, improving the material and improving the gas purification. The reduction in the weight of steel for the same output of nitrogen (Fig. 48) was accomplished through improved design, better lining material and better gas purification.

Fig. 49 gives a comparison between a blast furnace and an ammonia convertor.

Figs. 50-59 incl. are a further few photographs which illustrate the trend of progress from the first test convertor to the enormous Leuna works.

I am now coming to the end of my account. The development of the ammonia manufacturing process which partly as a result of Germany's isolation owing to the war, was perfected in a relatively short space of time by harnessing all our efforts and resources, has also of course stimulated the development of other reactions which proceed markedly better under high pressure than under atmospheric pressure. Experience has shown that in general it is often much more economical to operate at high pressure but even when the technical high pressure synthesis has been mastered, measures must be taken to ensure that the partial pressures, whether of the reaction gases or of the impurities, are correspondingly high.

Let us assume that 0.01% CO has to be removed from a gas mixture. Technically, at the high speed of the gas flow and low pressure, this is practically impossible by scrubbing with an absorbent, but very easy at 200 atm. with a carbon monoxide partial pressure of 1/50 atm.

Right at the outset of our studies we looked into the reduction of carbon monoxide with hydrogen and found that liquid reaction products could be obtained which proved to be mixtures of aliphatic alcohols, aldehydes, ketones and acids derived from them.⁷ Not until later (early 1923) was it realized⁸ that the first reaction product, *methyl alcohol*, is only formed in quantity if gas free from iron carbonyl and iron-free contact catalysts (particularly ZnO-Cr₂O₃) is used and the influence of iron vessel walls avoided as they condense methyl alcohol. The optimum operating conditions to achieve high yields of pure methyl alcohol were soon found, thereby facilitating the very rapid development of the synthesis, so that to-day methanol has become one of the cheapest

products of the chemical industry. Possibly the annual production by the high pressure method of synthesis is not less than 40,000 tons.

A further reaction which very soon claimed attention is the manufacture of *urea* from carbon dioxide and ammonia with the formation of water.⁹

When a mixture of carbon dioxide and ammonia or ammonium carbamate is heated to 130-140°C in a closed vessel, a mixture of urea and water plus carbon dioxide and ammonia is formed. The equilibrium is favourable at about 40% of the theoretical yield of urea. If such a mixture were allowed slowly to cool, the water formed would re-saponify most of the urea and so impair the yield. Furthermore the thermal economy would be very poor. We therefore separate the reaction mixture by distillation at high pressure by suctioning off the excess ammonia and the carbon dioxide using heated compressors and condensing the gases again above the solidification point.

Fig. 60 gives an illustration of the compressors used for that purpose. By this process we are able to produce about 40,000 tons of urea annually at our Oppau works.

Besides other, less important, pressure processes coal hydrogenation has attracted particular interest in recent years. As he will shortly report, Bergius had found that when coal is heated with hydrogen under pressure, large quantities of liquid reaction products are formed. In our laboratories it was subsequently ascertained that by using catalysts these reactions can be better controlled and may yield any products from light hydrocarbons to lubricating oil. After Bergius' basic patents had been acquired this process was introduced on a wide scale in Oppau and Leuna on the basis of our experience with the high pressure process and catalyst manufacture and currently provides 120,000 tons of benzine a year.

Most of the large oil companies also acquired the process for the hydrogenation of crude oils that are not readily processed. The present economic situation and the keen competition on the oil market have held up development. Nevertheless these processes are destined to play a very important part in the future.

Finally, I would like to draw your attention to another photograph (Fig. 61) of a large convertor in our coal hydrogenation plant. This shows the sizes we have reached (over-all length of convertor 18 m). Only on a mass production scale can these processes compete with the natural products.

I have to-day been able to inform you about only a small section of the work which has been carried out in our firm since 1908 in the field under discussion.

It scarcely need be added that this achievement has only been made possible by a large staff of colleagues. It is probably true to assert that such numbers have never before been engaged on one single problem. I sincerely wish to mention in particular two colleagues present here to-day who threw themselves heart and soul into our work from the very outset, namely Dr. Mit-tasch, head of the scientific laboratory, and Dr. Lappe who was in charge of technical development. To them I would like to acknowledge now my grati-tude for their unstinting, loyal co-operation.

1. D.R.P., 292, 615 (1912).
2. D.R.P., 249, 447, Jan. 9, 1910, together with supplements.
3. D.R.P., 291, 582 (1912); 298, 199 (1913) and 306, 333 (1916).
4. D.R.P., 254, 571 (Febr. 12, 1911) and 256, 296 (Sept. 6, 1911).
5. D.R.P., 265, 295 (1912).
6. Zentralstelle Neubabelsberg, D.R.P., 290, 877 (1913).
7. D.R.P., 293, 787 (1913).
8. Various patents issued in 1923 and subsequent years.
9. D.R.P., 295, 075 (1915) and 301, 279 (1916) and others.

[For Figs. 51-61 incl., see pages 236-241.]

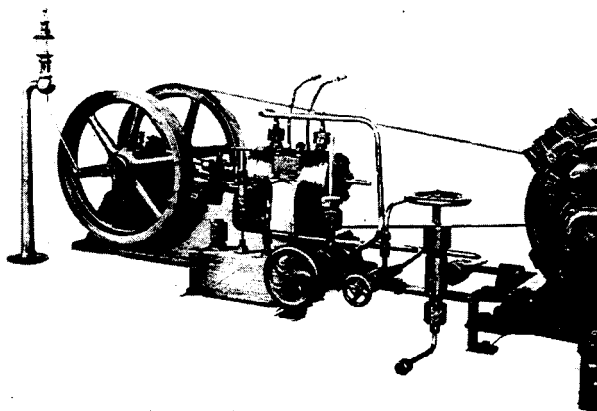

Fig. 51. Experimental circulating pump. August 1910.

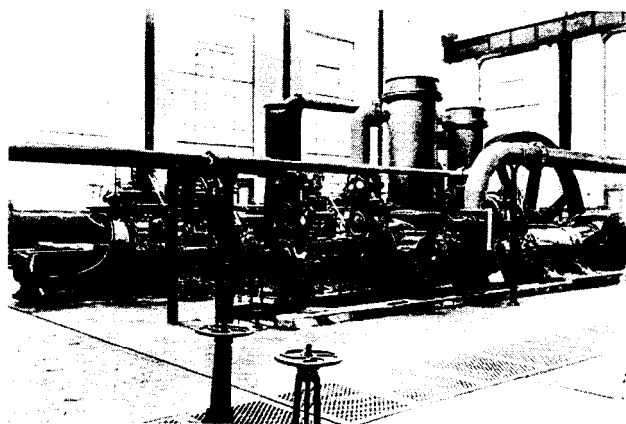

Fig. 52. High pressure compressor 1,000 h.p.

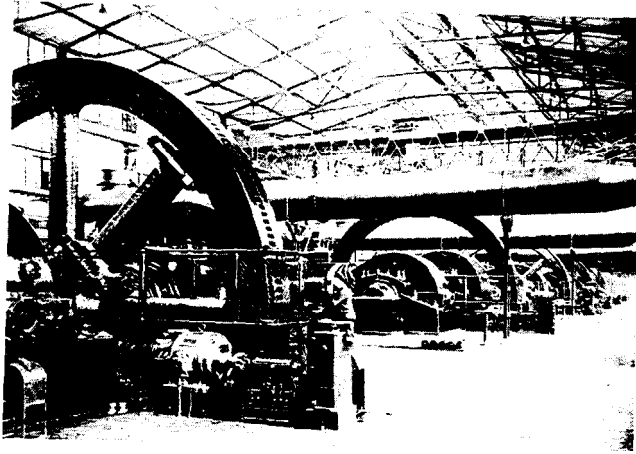

Fig. 53. High pressure compressor 3,000 h.p.

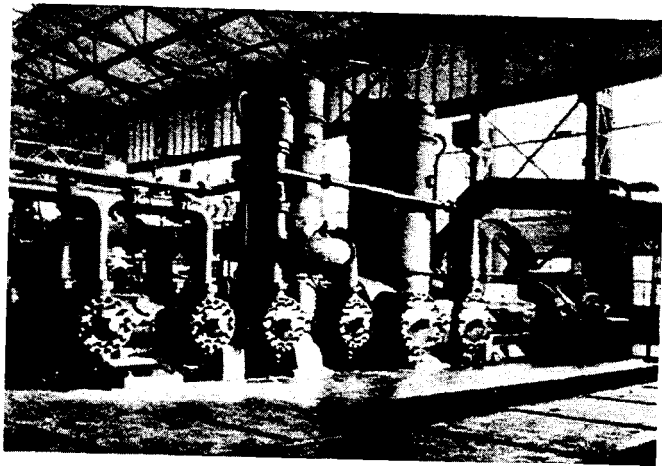

Fig. 54. High pressure compressor 3,000 h.p.



Fig. 55. High pressure lye pumps for gas purification.

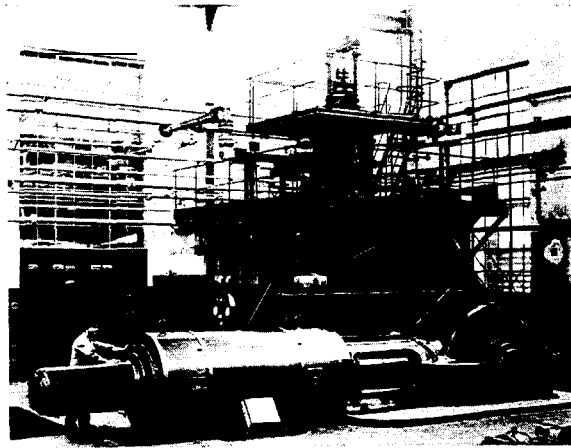

Fig. 56. Large piston circulating pump.



Fig. 57. Oppau works.



Fig. 58. Ammonia works at Merseburg.

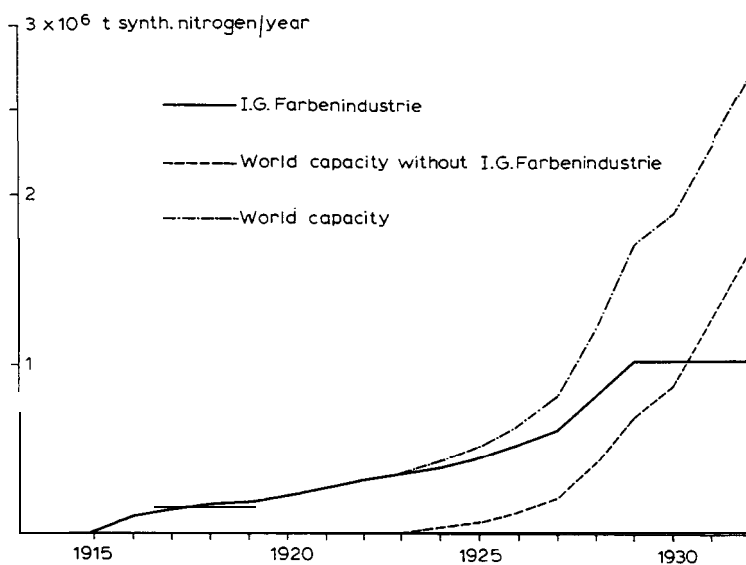

Fig. 59. World and I.G. Farbenindustrie annual capacity in tons of synthetic nitrogen.

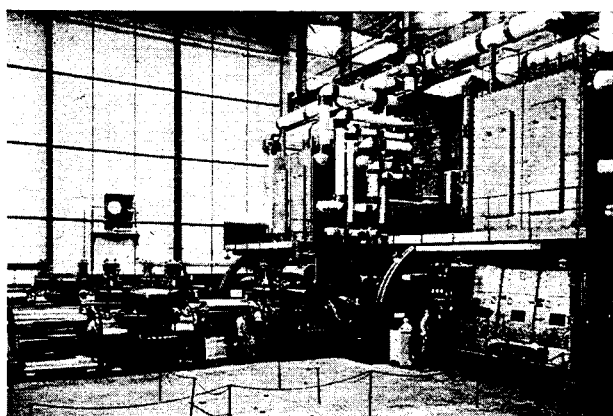

Fig. 60. Heated high pressure compressors for urea factory.

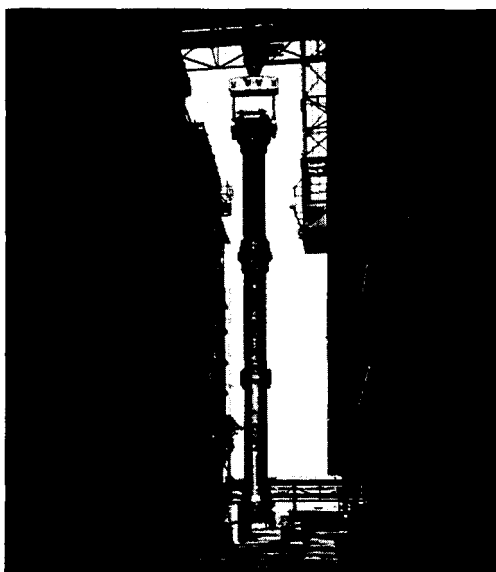

Fig. 61. Converter and high pressure chambers of hydrogenation plant.