



Review

The prediction of school achievement from a behavior genetic perspective: Results from the German twin study on Cognitive Ability, Self-Reported Motivation, and School Achievement (CoSMoS)

Juliana Gottschling^{a,*}, Marion Spengler^a, Birgit Spinath^b, Frank M. Spinath^a

^a Department of Psychology, Saarland University, Campus A1 3, D-66123 Saarbruecken, Germany

^b Department of Psychology, Heidelberg University, Hauptstraße 47-51, D-69117 Heidelberg, Germany

ARTICLE INFO

Article history:

Available online 17 February 2012

Keywords:

General cognitive ability
Self-perceived abilities
School achievement
Twin study CoSMoS

ABSTRACT

Much phenotypic research aims to identify which individual and familial characteristics explain individual differences in academic achievement. Behavior genetic studies can add informative value by analyzing the sources of this variation. The objective of the present study was to investigate the genetic and environmental origins of academic achievement and of two important and widely accepted predictors of school achievement, i.e. general cognitive ability (CA) and domain-specific self-perceived abilities (SPA). Results are based on cross-sectional data from the German twin study CoSMoS (97 MZ twin pairs, 183 DZ twin pairs; mean age 13.1 years, SD = 0.87). In line with previous research we confirmed the significance of genetic influences for all three variables, yielding heritability estimates between 30% and 62%. Multivariate genetic analyses further indicated that the genetic correlations between the variables were substantial and that SPAs in two school domains (German and Math) correlated with academic achievement for genetic rather than environmental reasons.

© 2012 Elsevier Ltd. All rights reserved.

1. Introduction

Measures of general cognitive ability (*g*) correlate with measures of achievement at approximately 0.50 (e.g., Gustafsson & Undheim, 1996), identifying *g* as the most important single predictor of achievement. More recently, researchers are addressing the question of which constructs explain the remaining 75% of the variance in school achievement. Children's motivational characteristics and especially their self-perceived abilities (SPAs) have been shown to be promising candidates (e.g., Spinath, Spinath, Harlaar, & Plomin, 2006; Steinmayr & Spinath, 2009). In the expectancy-value model by Eccles and colleagues (Eccles (Parsons) et al., 1983; Wigfield & Eccles, 2000) – a well established theory applicable to school contexts – it is presumed that SPAs are the key variables influencing future achievement. Typically, SPAs are assessed by self-reports about how *good* people think they are in a specific domain. Many studies have confirmed moderate relations between SPAs and school achievement within domains, mostly ranging between 0.40 and 0.60 (e.g., Guay, Marsh, & Boivin, 2003; Marsh, Smith, Barnes, & Butler, 1983). So far, intelligence and SPAs have rarely been considered in the same study. Results from such

studies (Gose, Wooden, & Muller, 1980; Schicke & Fagan, 1994; Spinath et al., 2006; Steinmayr & Spinath, 2009) converge in that SPAs contributed to the prediction of school achievement after intelligence was controlled, explaining incremental variance between 3% and 8%. Additionally, a substantial portion of variance in school achievement has been explained by what *g* and motivation had in common (Spinath et al., 2006).

Behavior genetic findings indicate that the heritability of intelligence increases from childhood to adulthood (from around 40% in middle childhood to around 60% in adulthood) whereas shared environmental effects show a reverse trend with high influences in early childhood and negligible influences after adolescence (e.g., Plomin, DeFries, McClearn, & McGuffin, 2008; Plomin & Spinath, 2004). With regard to school achievement, heritability estimates of approximately 60% have been reported for different school subjects while estimates for the effects of shared environment have been significantly lower (e.g., Bartels, Rietveld, Van Baal, & Boomsma, 2002; Johnson, McGue, & Iacono, 2006). Results from the Twins' Early Development Study (TEDS, Oliver & Plomin, 2007) suggested that genetic effects contribute to the same extent to continuity and change in academic performance (Kovas, Haworth, Dale, & Plomin, 2007).

At present, behavior genetic findings regarding SPAs are few but the results that have been reported appear to be at odds with theoretical assumptions from the original model in which environmental circumstances – such as parental beliefs, expectations, or

* Corresponding author. Tel.: +49 681 302 64238; fax: +49 681 302 4791.

E-mail addresses: j.gottschling@mx.uni-saarland.de (J. Gottschling), m.spengler@mx.uni-saarland.de (M. Spengler), birgit.spinath@psychologie.uni-heidelberg.de (B. Spinath), f.spinath@mx.uni-saarland.de (F.M. Spinath).

behaviors – are considered to be the primary sources of children's inter-individual differences in SPAs (Eccles (Parsons) et al., 1983; Wigfield & Eccles, 2000). In TEDS, for example, the reported heritability estimates for a global measure of SPA (combining SPAs in English, Math, and Science in one latent factor) were around 0.50 at ages 9 and 12 whereas shared environmental effects were negligible (Greven, Harlaar, Kovas, Chamorro-Premuzic, & Plomin, 2009; Luo, Haworth, & Plomin, 2010). Multivariate genetic analyses indicated that genetic influences were the primary source of the covariation among intelligence, SPA, and school achievement (e.g., Bartels et al., 2002) and that SPAs predicted school achievement, independently of intelligence, mainly as a result of genetic influences (Greven et al., 2009).

To contribute further to the understanding of the genetic and environmental influences on SPAs as well as genetic and environmental influences on the association between intelligence, SPAs, and achievement, we used a genetically informative design based on a sample of 13-year old German twins. SPAs were operationalized domain-specifically for the school subjects German and Math. This allowed us to explore the genetic and environmental contributions to inter-individual differences in domain-specific SPAs in a German twin sample.

2. Method

2.1. Participants

The sampling frame was the German twin study CoSMoS, which was initiated in 2005. So far, three measurements with two-year periods in between have been completed (see Spinath & Wolf, 2006, for details of the sampling procedure).

The data in this analysis were collected in the 2009 assessment. They consisted of 280 pairs of twins who participated in at least two of the three surveys and included 97 pairs of monozygotic (MZ), 94 pairs of dizygotic (DZ) same-sex twins, and 89 pairs of dizygotic opposite-sex twins (mean age = 13.1, SD = 0.87, 51.9% female). Zygosity was assessed by questionnaire, a method that typically yields accuracies around 95% (Price et al., 2000).

2.2. Measures and procedure

2.2.1. General cognitive ability

Cognitive ability (CA) was assessed via telephone by trained experimenters to ensure adherence to the standardized start and stop criteria (cf. Petrill, Rempell, Dale, Oliver, & Plomin, 2002). The test battery consisted of two verbal (*general knowledge* including 18 items and 25 *vocabulary items*) and two nonverbal (*figural classification* and *figural reasoning* consisting of 25 items each) scales adapted from the German Cognitive Ability Test (KFT 4–12 + R; Heller & Perleth, 2000) and the Wechsler Intelligence Scale for Children (WISC-III; Wechsler, 1991). A factor analysis of the four cognitive ability scales clearly favored a general factor model with the first factor accounting for 51% of the variance.

2.2.2. Self-perceived abilities

The questionnaire assessing SPAs was completed at the participants' homes either in paper-and-pencil or on-line format. Children's SPAs for Math and German were assessed by means of three items each. Children were asked to indicate on a 5-point scale ranging from very good (1) to *not good at all* (5) how good they thought they were in the following activities: *number puzzles or text task, mental arithmetic and multiplying/dividing* (Math) and *reading, writing and orthography* (German). Internal consistencies for the SPA scales were good to satisfactory (Cronbach's alpha of 0.82 (Math) and 0.70 (German)).

2.2.3. School achievement

Mid-term and full-term school grades served as indicators for school achievement in Math and German. Because the mark indicating excellence in the German system is 1, coding of grades was reversed so that higher values represent better performances.

3. Results

3.1. Phenotypic analyses

The scores of CA, SPAs and achievement were regressed on age and sex (McGue & Bouchard, 1984). Standardized residual scores were then used in a latent-factor model of CA (with the four cognitive tests as indicators), SPAs (with the three SPA items per subject as indicators), and achievement (with mid-term and full-term school grades as indicators) separately for Math and German. The phenotypic latent-factor model corresponded with the genetic common-pathway model displayed in Fig. 1. Incomplete data was handled using the expectation maximization algorithm implemented in SPSS 18, since the missing data pattern was completely at random (Little & Rubin, 2002).

Table 1 lists the latent factor correlations calculated with Mx (Neale, Boker, Xie, & Maes, 2004) as well as the loadings of the specific measures on the latent factors.

All phenotypic correlations (except the one between CA and SPA German) were modest to moderate and comparable for Math and German ($r = 0.23$ – 0.46 , $p < 0.01$; $r = 0.41$ – 0.47 , $p < 0.01$, respectively). All factor loadings were moderate to high indicating that the common variance among the measures was adequately captured by the latent factors.

3.2. Genetic analyses

Genetic analyses were based on the standard assumptions of the classical twin design (CTD; Plomin et al., 2008; for a detailed description of the design and its application refer to Spinath & Johnson, 2011). In this basic quantitative genetic model, the observed phenotypic trait variance is partitioned into additive genetic (A), non-additive genetic (D), shared environmental (C), and nonshared environmental (E) variance components where D and C are confounded in the CTD and therefore cannot be estimated simultaneously (Ozaki, Toyoda, Iwama, Kudo, & Ando, 2011). Whether D or C is estimated in a particular model depends on the pattern of MZ and DZ twin similarities, calculated as intraclass correlations (ICC). Shared environmental influences are assumed if MZ twins are less than twice as similar as DZ twins. In contrast, dominance can be assumed if MZ twin intraclass correlations exceed half the DZ correlations.

3.2.1. Intraclass correlations

Twin similarity was calculated as ICCs based on scale scores for CA, SPA Math and SPA German as well as school achievement in Math and German. As can be seen in the last two columns of Table 1, ICCs for MZ twins exceeded DZ ICCs for all measures, indicating the contribution of additive genetic influences. For CA and achievement, MZ correlations were less than twice the DZ correlations, suggesting some contribution of shared environmental effects. Finally, ICCs for CA and achievement were generally higher than for SPAs, thus nonshared environmental influences appeared to be of greater importance for SPAs than for the former variables.

3.2.2. Model-fitting analyses

We applied maximum-likelihood model fitting procedures using Mx (Neale et al., 2004) to estimate the relative contributions of genetic and environmental influences on the latent variables CA,

a Math

b German

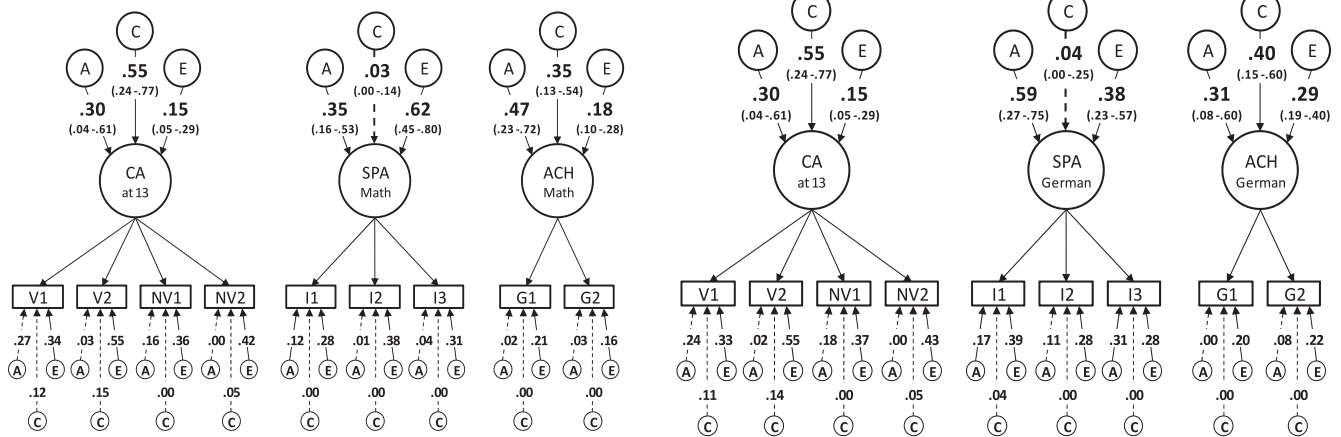

Fig. 1. Results of common-pathway model analyses of genetic (A), shared environmental (C), and nonshared environmental (E) influences on the latent factors of CA, SPAs, and ACH for Math (a) and German (b). The path estimates of common A, C, and E influences on CA, SPA and ACH are shown in the upper section of each diagram. Numbers in parentheses reflect 95% confidence intervals. Path estimates of specific A, C, and E influences are shown in the bottom section of each diagram (95% confidence intervals are given in Fig. 2). All path estimates are standardized and squared to refer to the percentage of variance explained, non-significant paths are represented as dashed lines.

SPA and achievement as well as their covariation. Three fit indicators were used to evaluate the model fit. Overall goodness-of-fit was assessed with χ^2 and Akaike's information criterion (AIC; Akaike, 1987). AIC was used to compare the fit of non-nested models with a lower AIC value indicating a better fit. Additionally, the root-mean-square error of approximation (RMSEA) was used. RMSEA values less than or equal to 0.01, 0.05, and 0.08 indicate excellent, good, and acceptable fit to the data (MacCallum, Browne, & Sugawara, 1996). Nested models were compared by means of χ^2 difference (LRT) tests.

3.2.2.1. Common-pathway models. We used the common-pathway model to estimate genetic and environmental contributions to the variation of CA, domain-specific SPA and domain-specific school achievement. Two types of A, C and E influences can be distinguished in these models: First, the latent phenotypes (CA, SPAs and achievement) can be partitioned into common A, C, and E influences on each latent factor. Additionally, the unique variance of each indicator is decomposed into specific genetic and environmental components (Young, Stallings, Corley, Krauter, & Hewitt, 2000). Thus, nine sets of specific A, C and E factors as well as three sets of common A, C and E factors were estimated separately for Math and German.

Figure 1 includes the parameter estimates for the full models in the domains of Math and German, respectively. We fitted the full model first and subsequently dropped the common C path for SPA as well as all specific C paths as they were non-significant in the full model (illustrated as dashed lines in Fig. 1). Table 2 summarizes the fit statistics for the full and the nested models for both Math and German. The full models (M1 and M3) provided acceptable fits to the data, similar to those of the reduced models (M2 and M4). In accordance with the rule of parsimony and since the reduced models did not fit significantly worse than the full models, the reduced models were chosen as the final models and all further analyses were based on these models.

On the basis of these models (see also Fig. 2), moderate genetic influences were found for CA (0.30) and achievement in Math and German (0.44 and 0.38, respectively), as was expected in this age group. For SPAs, heritability estimates were 0.38 for Math and 0.62 for German. CA and both achievement factors showed modest to moderate shared environmental influences (0.34–0.55) and modest nonshared environmental influences (0.15–0.27). As

mentioned above, we found no C influences for SPAs in Math and German but there were moderate to high E influences on the latent factors (0.62 and 0.38, respectively). It needs to be noted that E effects on the latent factors (CA, SPA and achievement) in the common-pathway model do not include measurement error. Thus, common E effects can be interpreted as true nonshared environmental influences. We also found some specific genetic influences especially for the two verbal CA scales (0.21–0.42) and two of the SPA items (0.12–0.31). Additionally, moderate specific E influences, ranging from 0.16 to 0.51, were identified for all of the nine indicators.

3.2.2.2. Relations among CA, SPA and achievement. We conducted Cholesky decompositions (Neale & Maes, 2004) to examine the genetic and environmental relations among the latent factors. As shown in Fig. 2, the genetic variance can be split into three components: (1) a general genetic factor (A_1) that influences all three variables, (2) a genetic factor (A_2) that influences only the second and third variable but is independent of A_1 , and (3) a specific genetic factor (A_3) influencing only the third variable. The same logic applies to the variance due to shared (C_1, C_2, C_3) and nonshared (E_1, E_2, E_3) environmental effects. The Cholesky decomposition can be used to (a) determine the importance of genetic and environmental influences on the association between the latter two variables independent of their influence on the first, and (b) to analyze the extent to which genetic as well as shared and nonshared environmental influences on CA, SPA and achievement overlap (=genetic (r_A), shared environmental (r_C) and nonshared environmental (r_E) correlation).

Focusing on the role of genetic and environmental influences in the relation between SPA and achievement independent of CA, the Cholesky analyses indicated for Math that the same genetic factors that accounted for 30% of the variance in CA (A_1) also accounted for 29% of the variance in achievement (Fig. 2a). They also contributed to the variance in SPA (8%) however, this path was nonsignificant. Even though nonsignificant, 10% of the variance in achievement can independently be explained through genetic factors associated with SPA (A_2). Only 5% of the genetic variance in achievement (A_3) was independent of CA and SPA. Reverse patterns were observed for both environmental influences. They were measure-specific for the largest part. Results for the German data were comparable (Fig. 2b).

Table 1
Latent factor correlations, loadings of the specific measures on the latent factors and intraclass correlations of the scale scores.

Measure	Correlations		Factor loadings									Intraclass Correlation	
	2	3	General cognitive ability				Self-perceived ability			Achievement		MZ	DZ
			V1	V2	NV1	NV2	I1	I2	I3	G1	G2		
<i>Math</i>													
1 CA	0.23**	0.46**	0.67	0.59	0.53	0.61						0.69 [0.51; 0.79]	0.57 [0.42; 0.67]
2 SPA		0.43**					0.77	0.78	0.81			0.44 [0.27; 0.59]	−0.04 [−0.18; 0.11]
3 ACH										0.89	0.88	0.75 [0.65; 0.83]	0.47 [0.35; 0.57]
<i>German</i>													
1 CA	0.06	0.47**											
2 SPA		0.41**					0.64	0.77	0.65			0.54 [0.38; 0.66]	0.24 [0.09; 0.37]
3 ACH										0.84	0.89	0.67 [0.54; 0.77]	0.50 [0.38; 0.60]

Note: $N = 560$. CA = general cognitive ability, SPA = self-perceived abilities, ACH = School Achievement, V1 = verbal test 1 (vocabulary), V2 = verbal test 2 (general knowledge), NV1 = nonverbal test 1 (figural classification), NV2 = nonverbal test 2 (figural reasoning); I1 = Item 1, I2 = Item 2, I3 = Item3; G1 = Mid-term grade in Math and German, respectively, G2 = Full-term grade in Math and German, respectively; MZ = monozygotic twins, DZ = dizygotic twins; * $p < 0.05$, ** $p < 0.01$ (two tailed); numbers in parentheses are 95% confidence intervals.

Table 2
Fit statistics and model comparison.

	Compare	χ^2	df	p	AIC	RMSEA	$\Delta\chi^2$	Δdf	p
M1: full model Math		539.45	288	0.00	−36.55	0.08			
M2: reduced model Math	M2 vs. M1	545.72	300	0.00	−54.28	0.08	6.27	12	0.90
M3: full model German		535.82	288	0.00	−40.02	0.08			
M4: reduced model German	M4 vs. M3	541.67	300	0.00	−58.33	0.08	5.69	12	0.93

Note: $N = 97$ MZs and 183 DZs; M1, M3 = Model with 9 sets of specific A, C and E factors and 3 sets of common A, C and E factors, M2, M4 = Model with dropped non-significant C paths; df = degrees of freedom; p = significance level; AIC = Akaike's information criterion; RMSEA = root mean square error of approximation, $\Delta\chi^2$ = likelihood ratio χ^2 test with Δdf degrees of freedom; best fitting model marked bold.

Finally, Table 3 provides the genetic, shared environmental and nonshared environmental correlations among CA, SPA (Math and German) and achievement (Math and German), calculated on the basis of the Cholesky model depicted in Fig. 2. There was evidence for substantial genetic overlap among CA, SPA and achievement in the Math domain ($r_A = 0.45$ – 0.81) whereas in the German domain only the genetic correlations between CA and achievement and SPA and achievement reached significance ($r_A = 0.89$ and 0.59 , respectively). All shared and nonshared environmental correlations were nonsignificant, despite moderate nonshared environmental correlations between SPA and achievement for Math and German ($r_E = 0.29$ and 0.30 , respectively).

4. Discussion

The first objective of this study was to explore the genetic and environmental influences on SPA, a motivational construct that generally has predicted school achievement beyond general cognitive ability (e.g., Spinath et al., 2006; Steinmayr & Spinath, 2009). A second aim was to examine genetic and environmental influences on the covariation among CA, SPAs, and achievement. Behavior genetic findings in this field are still rare. So far, the only published uni- and multivariate genetic analyses of SPAs have come from TEDS, but the comparability with the presented results is somewhat restricted due to a different operationalization of SPAs (latent global factor vs. latent domain-specific factor) as well as school achievement (combination of teachers' ratings, self-ratings, and test scores vs. mid-term and full-term school grades) on the one hand and a different age group (9 year olds vs. 13 year olds) as well as a different country on the other hand.

Altogether, the most striking finding of the genetic analyses was that domain-specific SPAs were substantially genetically influenced. This general result corresponds with heritability estimates found for the global measure of SPA in TEDS (Greven et al., 2009). Furthermore, both CoSMoS and TEDS support the conclusion that inter-individual differences in children's beliefs about how good they think they are

at a specific task cannot be explained by shared environmental influences, as theorized by Eccles and colleagues (Eccles (Parsons) et al., 1983; Wigfield & Eccles, 2000). Instead, environmental influences on SPAs were mainly nonshared experiences that contributed to the dissimilarity of children growing up in the same family. These kinds of environmental influences explain as much variance in SPAs as genetic influences. But what does this finding imply for the malleability of SPAs? First, even high heritability estimates do not mean immutability of a trait in an individual (Plomin et al., 2008). Apart from that, the observed nonshared environmental influences emphasize the importance of an intraindividual perspective on SPAs. That is, the same event, whether it occurs inside or outside the family, may be experienced differently by two children (Plomin, Asbury, & Dunn, 2001). Following the same argument, the absence of shared environmental influences is not equivalent with the notion that family influences such as parenting style or parents' involvement in school issues do not matter. In fact, children might perceive such influences in different ways which as a consequence is reflected in nonshared environmental rather than in shared environmental influences (Harris, 1995).

One rather unexpected finding was that the heritability estimate of SPA in Math was substantially lower than that in German (0.38 vs. 0.62, respectively). This result was due to low ICCs for both MZs and DZs in Math, which were particularly pronounced in DZs (−0.04). It is possible that twins stress within-pair differences especially in areas which are easily observable or quantifiable in daily life. Following this line of reasoning, within-pair comparisons (which have been described as “contrast effects” in the twin literature, see Buss & Plomin, 1984) should more readily occur for Math-related tasks like *number puzzles*, *mental arithmetic* and *multiplying/dividing* than in more abstract capabilities like *reading*, *writing* and *orthography*.

Our multivariate genetic analyses provided evidence for overlaps of genetic influences among CA, SPA, and achievement, whereas environmental influences did not show considerable overlap. However, the genetic correlations were especially high

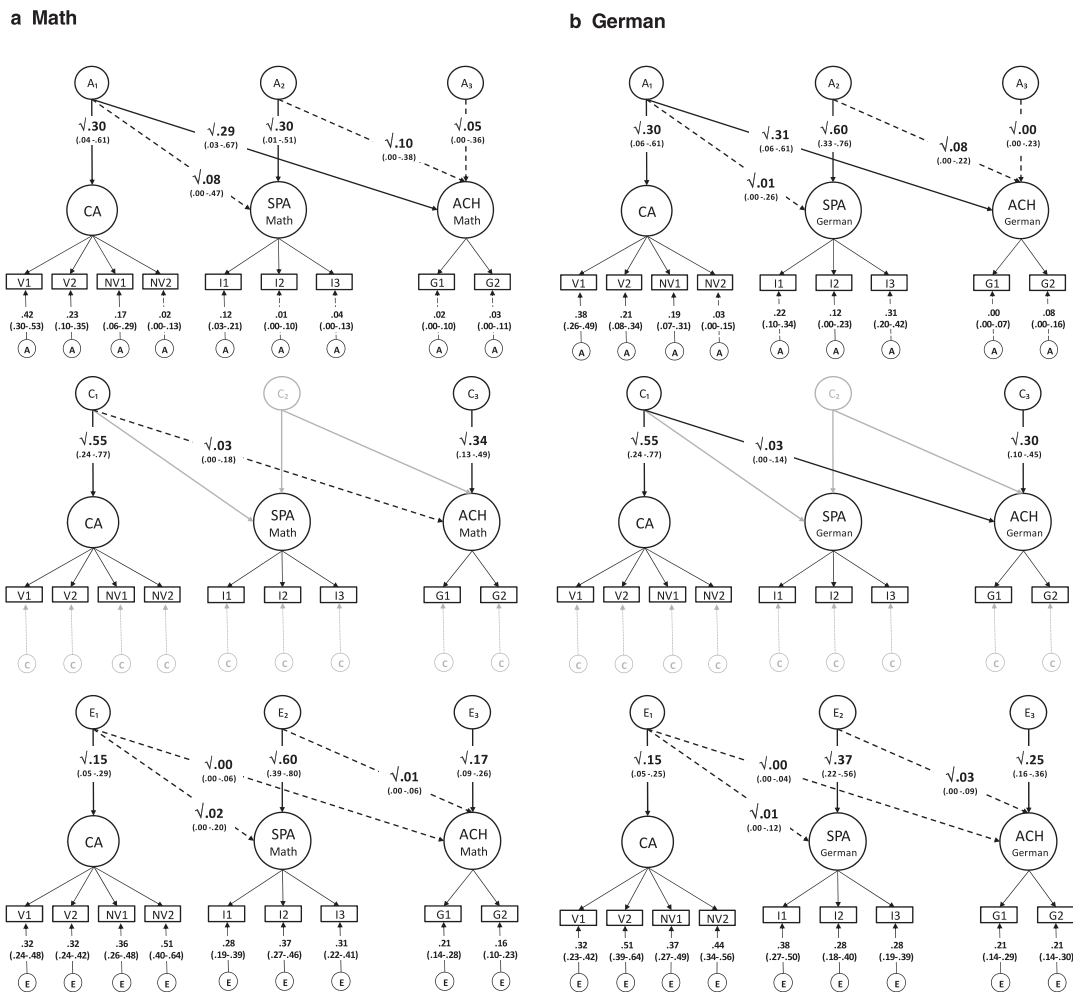

Fig. 2. Results from the Cholesky decomposition of genetic (A), shared environmental (C), and nonshared environmental (E) covariance among CA, SPA, and achievement. Results for Math (a) and German (b) as well as the estimates of the residual variance in the indicators are shown. All path estimates are standardized and squared to refer to the percentage of variance explained. Non-significant paths are represented as dashed lines, not estimated paths are represented as grey lines. Numbers in parentheses reflect 95% confidence intervals.

Table 3
Genetic, shared environmental, and nonshared environmental correlations.

Correlation	Math			German		
	CA–SPA	CA–Ach	SPA–Ach	CA–SPA	CA–Ach	SPA–Ach
Genetic (r_A)	0.45 [0.01; 1.00]	0.81 [0.27; 1.00]	0.79 [0.49; 1.00]	0.16 [–0.20; 0.66]	0.89 [0.51; 1.00]	0.59 [0.30; 0.62]
Shared environmental (r_C)		0.30 [–0.15; 0.69]			0.31 [–0.20; 0.58]	
Nonshared environmental (r_E)	0.20 [–0.13; 0.56]	0.16 [–0.23; 0.55]	0.29 [0.03; 0.52]	–0.16 [–0.54; 0.21]	–0.02 [–0.40; 0.32]	0.30 [0.04; 0.56]

Note: N = 97 MZs and 183 DZs; numbers in parentheses are 95% confidence intervals.

(i.e. >50%) between achievement and both SPAs and CA. One possible interpretation of this is pleiotropy (de Geus, 2011), i.e. a common set of genes influencing achievement and SPAs as well as CA. Genetic correlations, however, do not only occur if the same genes directly influence both traits. It is also possible that heritable trait A contributes to trait B or vice versa (Johnson, Penke, & Spinath, 2011) or that all three mechanisms co-exist (de Geus, 2011).

Results from the Cholesky decomposition suggest that genetic influences associated with CA and SPA accounted for almost the entire variance in achievement. The bulk of the variance in achievement was explained by genetic influences shared with CA and only a small proportion of the variance in achievement was independently explained by genetic influences associated with SPAs (10% in Math, 8% in German). This small amount of explained

variance was comparable with results reported in TEDS (Grevet et al., 2009). However, since the TEDS sample is substantially larger than the CoSMoS sample, the estimate reached significance in TEDS and failed to do so in the present analysis. In contrast to the genetic findings, nonshared environmental influences were largely measure-specific. This indicated that different nonshared experiences influenced CA, SPA and achievement.

5. Limitations

These results are to some extent limited in their generalizability. First, our sample size was rather small so that the power to detect significant effects is limited. A second constraint involved the cross-sectional nature of the data.

6. Conclusion

In sum, the results of the present investigation added to previous evidence indicating that SPAs are genetically influenced not only on global but also on domain-specific level. Our data also showed that the genetic share of school achievement variance could be completely explained by genetic factors associated with CA and SPAs. In line with previous research, we found that genetic factors associated with SPAs explained a small part of the genetic variance in achievement independent of CA.

References

- Akaike, H. (1987). Factor analysis and the AIC. *Psychometrika*, *52*, 317–332.
- Bartels, M., Rietveld, M. J. H., Van Baal, G. C. M., & Boomsma, D. I. (2002). Genetic and environmental influences on the development of intelligence. *Behavior Genetics*, *32*, 237–249.
- Buss, A. H., & Plomin, R. (1984). *Temperament: Early developing personality traits*. Hillsdale, NJ: Lawrence Erlbaum Associates, Inc.
- De Geus, E. (2011). The association between depression and heart disease: The role of genetic factors. In A. Glassman, M. Maj, & N. Sartorius (Eds.), *Depression and heart disease* (pp. 57–98). Chichester: John Wiley and Sons, Ltd.
- Eccles (Parsons), J., Adler, T. F., Futterman, R., Goff, S. B., Kaczala, C. M., & Meece, J. L. (1983). Expectancies, values, and academic behaviors. In J. T. Spence (Ed.), *Achievement and achievement motives* (pp. 75–146). San Francisco: Freeman.
- Gose, A., Wooden, S., & Muller, D. (1980). The relative potential of self-concept and intelligence as predictors of achievement. *Journal of Psychology*, *104*, 279–287.
- Greven, C. U., Harlaar, N., Kovas, Y., Chamorro-Premuzic, T., & Plomin, R. (2009). More than just IQ: School achievement is predicted by self-perceived abilities – but for genetic rather than environmental reasons. *Psychological Science*, *20*, 753–762.
- Guay, F., Marsh, H. W., & Boivin, M. (2003). Academic self-concept and academic achievement: Developmental perspectives on their causal ordering. *Journal of Educational Psychology*, *95*, 124–136.
- Gustafsson, J. E., & Undheim, J. O. (1996). Individual differences in cognitive functions. In D. C. Berliner & R. C. Calfee (Eds.), *Handbook of Educational Psychology* (pp. 186–242). New York: Prentice Hall International.
- Harris, J. R. (1995). Where is the child's environment? A group socialization theory of development. *Psychological Review*, *102*, 458–489.
- Heller, K. A., & Perleth, C. (2000). Kognitiver Fähigkeitstest für 4. bis 12. Klassen, Revision (KFT4-12+R). Weinheim: Beltz.
- Johnson, W., McGue, M., & Iacono, W. G. (2006). Genetic and environmental influences on academic achievement trajectories during adolescence. *Developmental Psychology*, *42*, 514–532.
- Johnson, W., Penke, L., & Spinath, F. M. (2011). Heritability in the era of molecular genetics: Some thoughts for understanding genetic influences on behavioural traits. *European Journal of Personality*, *25*, 254–266.
- Kovas, Y., Haworth, C. M. A., Dale, P. S., & Plomin, R. (2007). The genetic and environmental origins of learning abilities and disabilities in the early school years. *Monographs of the Society for Research in Child Development*, *72*, vii–160.
- Little, R. J. A., & Rubin, D. B. (2002). *Statistical Analysis with Missing Data*. Hoboken: John Wiley and Sons.
- Luo, Y. L., Haworth, C. M. A., & Plomin, R. (2010). A novel approach to genetic and environmental analysis of cross-lagged associations over time: The cross-lagged relationship between self-perceived abilities and school achievement is mediated by genes as well as the environment. *Twin Research and Human Genetics*, *13*, 426–436.
- MacCallum, R. C., Browne, M. W., & Sugawara, H. M. (1996). Power analysis and determination of sample size for covariance structure modeling. *Psychological Methods*, *1*, 130–149.
- Marsh, H. W., Smith, I. D., Barnes, J., & Butler, S. (1983). Self-concept: Reliability, stability, dimensionality, validity, and the measurement of change. *Journal of Educational Psychology*, *75*, 772–790.
- McGue, M., & Bouchard, T. J. (1984). Adjustment of twin data for the effects of age and sex. *Behavior Genetics*, *14*, 325–343.
- Neale, M. C., & Maes, H. H. (2004). *Methodology for Genetic Studies of Twins and Families*. Dordrecht: Kluwer Academic Publishers.
- Oliver, B. R., & Plomin, R. (2007). Twins' early development study (TEDS): A multivariate, longitudinal genetic investigation of language, cognition and behavior problems from childhood through adolescence. *Twin Research and Human Genetics*, *10*, 96–105.
- Ozaki, K., Toyoda, H., Iwama, N., Kudo, S., & Ando, J. (2011). Using nonnormal SEM to resolve the ACDE model in the classical twin design. *Behavior Genetics*, *41*, 329–339.
- Petrill, S. A., Rempell, J., Dale, P. S., Oliver, B., & Plomin, R. (2002). Testing cognitive abilities by telephone in a sample of 6-to 8-year olds. *Intelligence*, *30*, 353–360.
- Plomin, R., Asbury, K., & Dunn, J. (2001). Why are children in the same family so different? Nonshared environment a decade later. *Canadian Journal of Psychiatry*, *46*, 225–233.
- Plomin, R., DeFries, J. C., McClearn, G. E., & McGuffin, P. (2008). *Behavioral Genetics* (5th ed.). New York: Worth.
- Plomin, R., & Spinath, F. M. (2004). Intelligence: Genetics, genes, and genomics. *Journal of Personality and Social Psychology*, *86*, 112–129.
- Price, T. S., Freeman, B., Craig, I., Petrill, S. A., Ebersole, L., & Plomin, R. (2000). Infant zygosity can be assigned by parental report questionnaire data. *Twin Research and Human Genetics*, *3*, 129–133.
- Schicke, M., & Fagan, T. K. (1994). Contributions of self-concept and intelligence to the prediction of academic achievement among grade 4, 6, and 8 students. *Canadian Journal of School Psychology*, *10*, 62–69.
- Spinath, F. M., & Johnson, W. (2011). Behavior genetics. In T. Chamorro-Premuzic, S. von Stumm, & A. Furnham (Eds.), *The Wiley-Blackwell handbook of individual differences* (pp. 271–304). Chichester: John Wiley and Sons, Ltd.
- Spinath, B., Spinath, F. M., Harlaar, N., & Plomin, R. (2006). Predicting school achievement from general cognitive ability, self-perceived ability, and intrinsic value. *Intelligence*, *34*, 363–374.
- Spinath, F. M., & Wolf, H. (2006). CoSMoS and TwinPaW: Initial Report on two new German twin studies. *Twin Research and Human Genetics*, *9*, 787–790.
- Steinmayr, R., & Spinath, B. (2009). The importance of motivation as a predictor of school achievement. *Learning and Individual Differences*, *19*, 80–90.
- Wechsler, D. (1991). *Manual for the Wechsler intelligence scale for children* (3rd ed.). San Antonio: The Psychological Corporation.
- Wigfield, A., & Eccles, J. S. (2000). Expectancy-value theory of achievement motivation. *Contemporary Educational Psychology*, *25*, 68–81.
- Young, S. E., Stallings, M. C., Corley, R. P., Krauter, K. S., & Hewitt, J. K. (2000). Genetic and environmental influences on behavioral disinhibition. *American Journal of Medical Genetics (Neuropsychiatric Genetics)*, *96*, 684–695.

Web References

- Neale, M. C., Boker, S. M., Xie, G., & Maes, H. H. (2004). *Mx: Statistical Modelling* (6th ed.). Richmond: Department of Psychiatry. Retrieved July 1, 2009, from <http://www.vipbg.vcu.edu/>.